

## Information Indicator and Information Display

The red information indicator (1) lights when there is any abnormality in the coolant temperature and/or engine oil pressure. As this happens, the coolant temperature indicator (2) and/or low oil pressure indicator (3) contained in the information display (5) will also go on.

The red information indicator flashes when there is any abnormality in the PGM-FI (Programmed Fuel Injection) system regardless of abnormality of others. As this happens, the PGM-FI indicator (4) contained in the information display (5) will also go on.

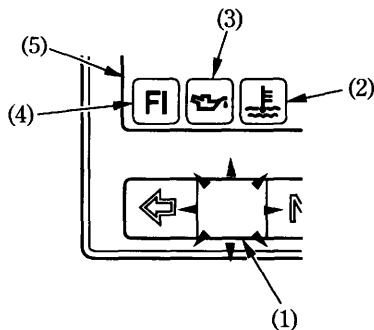

- (1) Information indicator
- (2) Coolant temperature indicator
- (3) Low oil pressure indicator
- (4) PGM-FI indicator
- (5) Information display