

WHEEL RIMS AND SPOKES

Refer to the Safety Precautions on page 44.

1. Inspect the wheel rims (1) and spokes (2) for damage.
2. Tighten any loose spokes and rim locks (3).
3. Check wheel rim runout. If runout is noticeable, see your Honda dealer for inspection.

Maintenance of spoke tension and wheel trueness are critical to safe motorcycle operation. During the first 150 km (100 miles), spokes will loosen more rapidly due to initial seating of parts. Excessively loose spokes may result in high speed instability and possible loss of control.

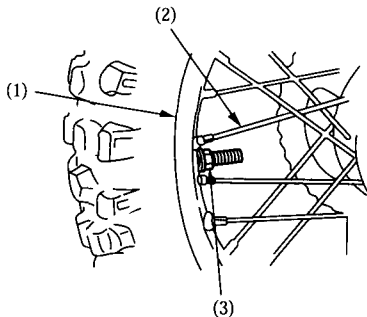

- (1) Wheel rim
(2) Spoke

- (3) Rim lock