

## VALVES

Valve clearance should be maintained properly. Excessive clearance will cause noise. Insufficient clearance will cause loss of power and could cause valve damage. If the valves are noisy, or if the engine lacks power, adjust the valve clearance as follows.

### NOTE:

\* Check and adjust valve clearance while the engine is cold. The clearance will change as the temperature rises.

1. Remove the valve adjuster cover (1) from the left of the cylinder head cover by removing the two bolts (2).

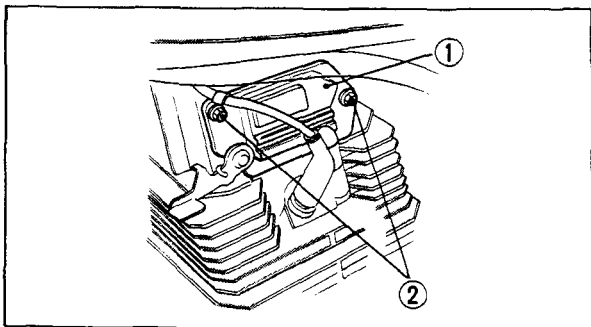

(1) Valve adjuster cover

(2) Bolts

2. Remove the timing indicator hole cap (3) between the intake adjuster (4) and the exhaust adjuster (5).
3. Remove the timing mark hole cap (8).
4. Using the recoil starter, rotate the crankshaft until the "T" mark (9) on the alternator rotor aligns with the timing index mark (10) on the left crankcase cover. Make sure the arrow (7) on the camshaft is visible through the timing indicator hole. If the arrow is not visible, rotate the crankshaft 360° (one complete revolution) and realign the "T" mark verify that the arrow is now visible.

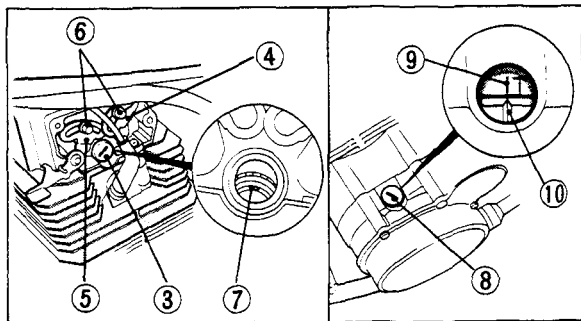

(3) Timing indicator hole cap

(4) Intake adjuster

(5) Exhaust adjuster

(6) Lock bolts

(7) Arrow

(8) Timing mark hole cap

(9) "T" mark

(10) Timing index mark