

### Adjustment:

Drive chain slack should be checked and adjusted, if necessary, every 1,000 km (600 miles). When operated at sustained high speeds or under conditions of frequent rapid acceleration, the chain may require more frequent adjustment.

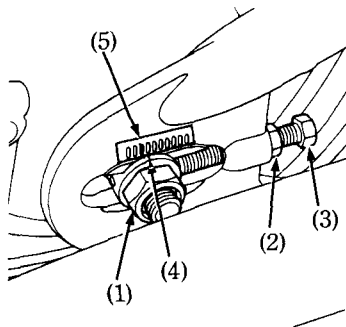

- |                                   |                         |
|-----------------------------------|-------------------------|
| (1) Axle nut                      | (4) Index mark          |
| (2) Lock nut                      | (5) Corresponding scale |
| (3) Drive chain<br>adjusting bolt |                         |

If the drive chain requires adjustment, the procedure is as follows:

1. Place the motorcycle on its side stand with the transmission in neutral and the ignition switch off.
2. Loosen the axle nut (1).
3. Loosen the lock nuts (2) on both adjusting bolts (3).
4. Turn both adjusting bolts an equal number of turns until the correct drive chain slack is obtained. Turn the adjusting bolts clockwise to tighten the chain, or counterclockwise to provide more slack. Adjust the chain slack at a point midway between the drive sprocket and the rear wheel sprocket. Rotate the rear wheel and recheck slack at other sections of the chain.

Chain slack should be:

20–30 mm (0.8–1.2 in)

5. Align the chain adjuster index marks (4) with the corresponding scale (5) graduations on both sides of the swing arm.