

## Installation

1. Attach the side collars to the wheel.
2. On the right side, place the wheel between the fork legs and insert the lightly greased front axle shaft to the end, through the right fork leg and wheel hub.
3. Align the end of the front axle shaft with the surface of the fork leg.

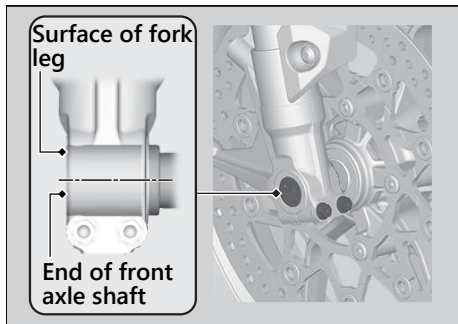

4. Tighten the right axle pinch bolts to hold the axle.

5. Tighten the axle bolt.

**Torque:** 44 lbf·ft (59 N·m, 6.0 kgf·m).

6. Loosen the right axle pinch bolts.
7. Tighten the left axle pinch bolts.

**Torque:** 16 lbf·ft (22 N·m, 2.2 kgf·m).

8. **CBR650RA only**

Secure the wheel speed sensor wire with the clamp.

