

# Suspension

Refer to *Safety Precautions* on [page 19](#).

Loose, worn, or damaged suspension components may adversely affect the handling and stability of your CRF. If any suspension components appear worn or damaged, see your dealer for further inspection. Your dealer is qualified to determine whether or not replacement parts or repairs are needed.

## Front Suspension Inspection

- When your CRF is new, break it in for approximately 1 hour to ensure that the suspension has worked in ([page 16](#)).
- After break-in, test run your CRF with the front suspension at the standard setting before attempting any adjustments.
- For optimum fork performance, we recommend that you disassemble and clean the fork after riding your CRF for 3 hours. See [page 94](#) for fork disassembly.
- Replace the fork oil every 3 races or 7.5 hours of running. See [pages 73, 74](#) for oil level adjustment after changing the fork oil.
- Use HP Fork Oil, SS-19 or an equivalent which contains special additives to assure maximum performance of your CRF's front suspension.
- Periodically check and clean all front suspension parts to assure top performance. Check the dust seals for dust, dirt, and foreign materials. Check the oil for any contamination.

- Refer to *Suspension Adjustment Guidelines* ([page 107](#)). Make all rebound and compression damping adjustments in 1/4 turn increments. (Adjusting 1/2 or more turns at a time may cause you to pass over the best adjustment.) Test ride after each adjustment.
- If you become confused about adjustment settings, return to the standard position and start over.
- If the fork is still too stiff/soft after adjusting compression damping, determine which portion of the travel is still too stiff/soft. This is an important step that will help you solve suspension problems.

1. Make sure that the fork protectors (1) and dust seals (2) are clean and not packed with mud and dirt.
2. Check for signs of oil leakage. Damaged or leaking fork seals should be replaced before your CRF is ridden.

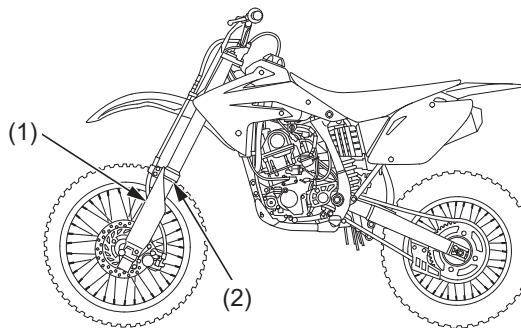

(1) fork protector (2) dust seal

3. Inspect the wear rings (3) for wear or damage. Replace the wear ring if it is 0.06 in (1.5 mm) or flat with the outer tube (4). Remove the fork leg when replacing the wear ring ([page 94](#)). Install the wear ring with its end gap (5) facing rearward.

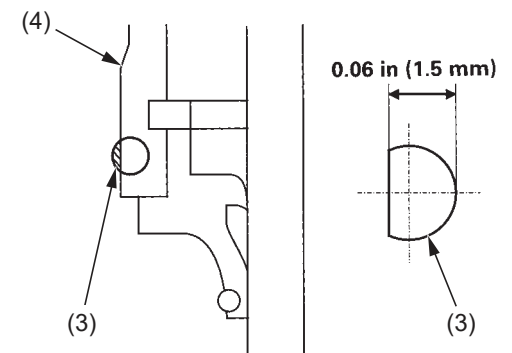

(3) wear ring (4) outer tube

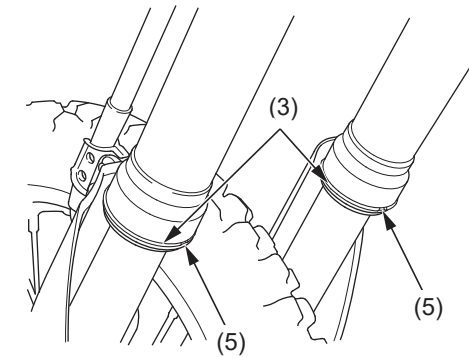

(3) wear rings (5) end gaps

4. Make a quick check of fork operation by locking the front brake and pushing down on the handlebar several times.

