

Front Suspension Adjustments

17. Clean the spring and spring seat thoroughly with a high flash point solvent to remove all metal particles and dirt.
18. Dry the spring and spring seat with air pressure rather than a shop towel. Using a shop towel allows lint to stick to the springs. Lint or any particles that stick in the damping passages can cause inconsistent damping.
19. Turn the adjuster needle rod (14) counterclockwise and remove it from the fork cap (2). Check the adjuster needle rod for bent or damage. Check that the O-rings (20) on the fork cap and needle rod are in good condition. Apply the recommended fork oil to the O-rings.

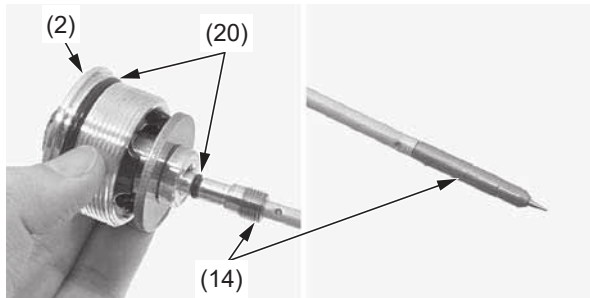

(2) fork cap
(14) adjuster needle rod
(20) O-rings

20. Loosen the lock nut (16) slightly.
21. Attach a two-foot length of mechanic's wire (21) to the threaded portion on the lock nut. Wrap the wire securely around the threads.

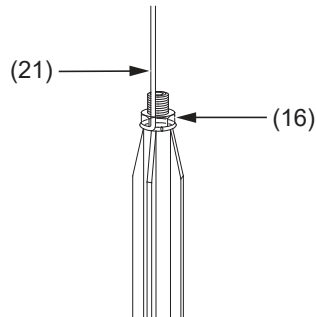

(16) lock nut
(21) mechanic's wire

22. Install the fork spring (17) as follows:
 - With the fork spring held upright on its marked end, feed the mechanic's wire up through the spring.
 - Angle the fork spring and slowly slide it down into the fork using a gentle rocking motion.
23. Reaching through the two adjacent coils near the oil lock valve, hold the spring guide (22) with your finger. Remove the mechanic's wire and hand tighten the lock nut (16) to the spring guide (22).

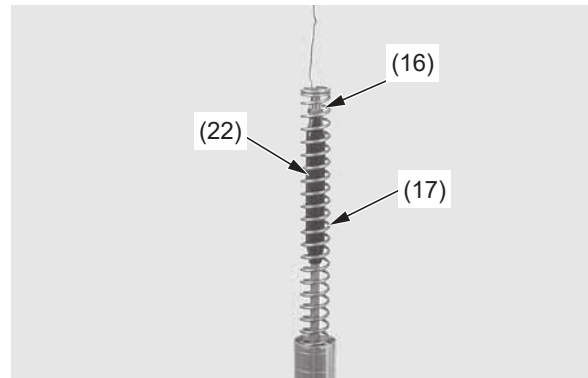

(16) lock nut
(17) fork spring
(22) spring guide

24. Set the adjuster screw (12) to 0.06 in (1.5mm) from the fork cap (2) top, then install the fork cap onto the piston rod.

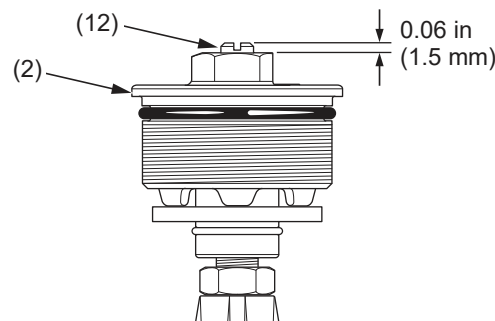

(2) fork cap
(12) adjuster screw

NOTICE

When installing the fork cap, be careful not to damage the damping force adjuster needle rod and the needle or the rod end.

25. Hand tighten the fork cap (2) on the piston rod (15) lightly until it stops, then tighten the lock nut (16) to the fork cap to the specified torque: 15 lbf·ft (19.7 N·m, 2.0 kgf·m)

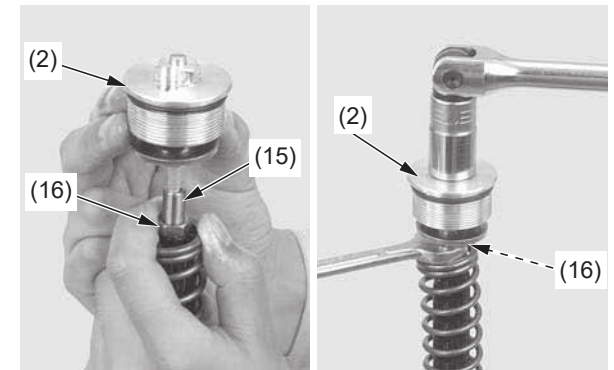

(2) fork cap
(15) piston rod
(16) lock nut

26. Temporarily thread the fork cap into the fork tube.
27. Insert both fork legs into the fork clamps