

Carburetor Adjustments & Tuning Tips

Accelerator Pump Circuit

The accelerator pump circuit operates when the throttle is opened. As the throttle valve (1) opens, the pump rod (2) depresses the diaphragm (3). At this time, the inlet check valve (4) is shut resulting in a sharp increase in pressure in the pump chamber (5). The outlet check valve (6) then opens, supplying fuel to the main bore via the accelerator nozzle (7). Leak jet (8) operation is related to both the length of time before the fuel starts flowing after the opening of the throttle (time lag) and the flow amount.

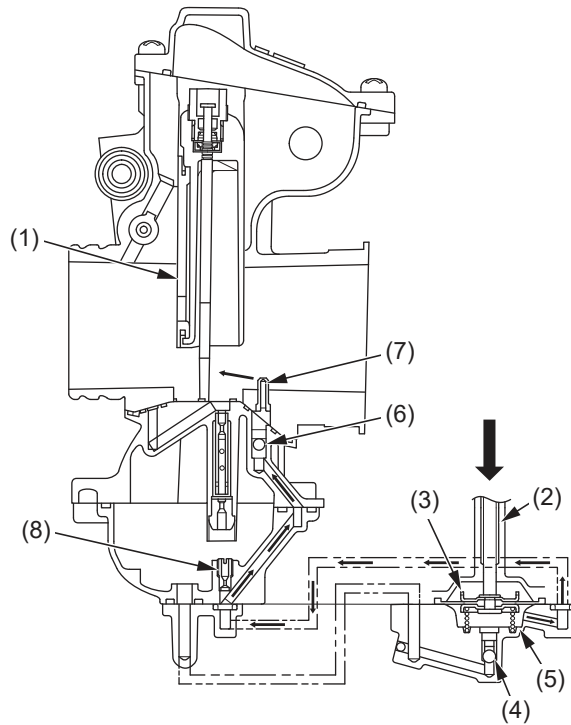

- (1) throttle valve
- (2) pump rod
- (3) diaphragm
- (4) inlet check valve
- (5) pump chamber
- (6) outlet check valve
- (7) accelerator nozzle
- (8) leak jet

Slow Circuit

Fuel is metered by the slow jet (1) and mixed with air from the air passage (2). The mixture enters the venturi through the bypass (3) and pilot outlet (4) that has been metered by the pilot screw (5).

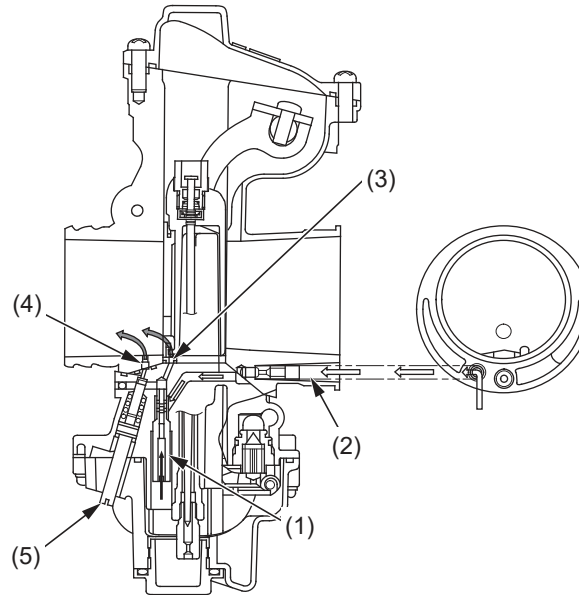

- (1) slow jet
- (2) air passage
- (3) bypass
- (4) pilot outlet
- (5) pilot screw

Main Circuit

Fuel is metered by the main jet (1), jet needle (2) and needle jet (3). It is then mixed with air coming from the air jet (4) and enters the venturi past the needle jet.

Baffle Plate

The baffle plate (5) prevents foaming of fuel or abnormal fuel level around the main jet.

Float Bowl

The float (6) and float valve (7) operate to maintain a constant level of fuel in the float bowl.

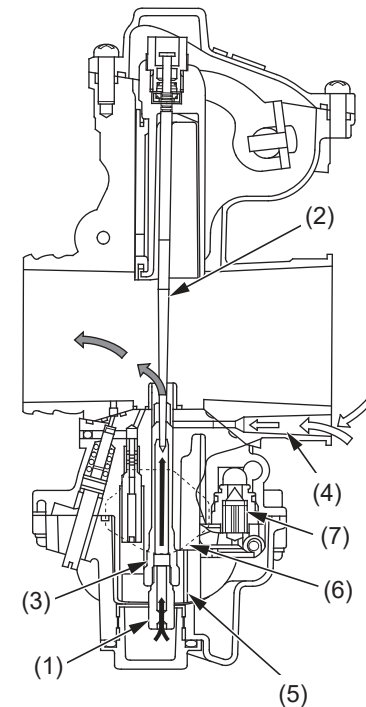

- (1) main jet
- (2) jet needle
- (3) needle jet
- (4) air jet
- (5) baffle plate
- (6) float
- (7) float valve