

# Brakes

## Brake Light Switch Adjustment

Refer to *Safety Precautions* on [page 73](#).

### Rear Brake Only:

Check the operation of the rear brake light switch (1) at the right side behind the engine from time to time. Remove the right side mudguard ([page 135](#)). Adjustment is done by turning the adjusting nut (2). Turn the nut in direction (A) if the switch operates too late and in direction (B) if the switch operates too soon.

### RIGHT SIDER

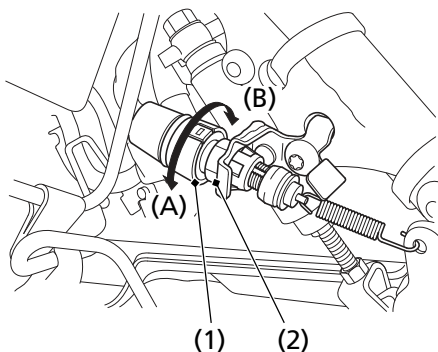

(1) brake light switch

(2) adjusting nut