



F-25

Tool

Outils

Werkzeug

Herramientas

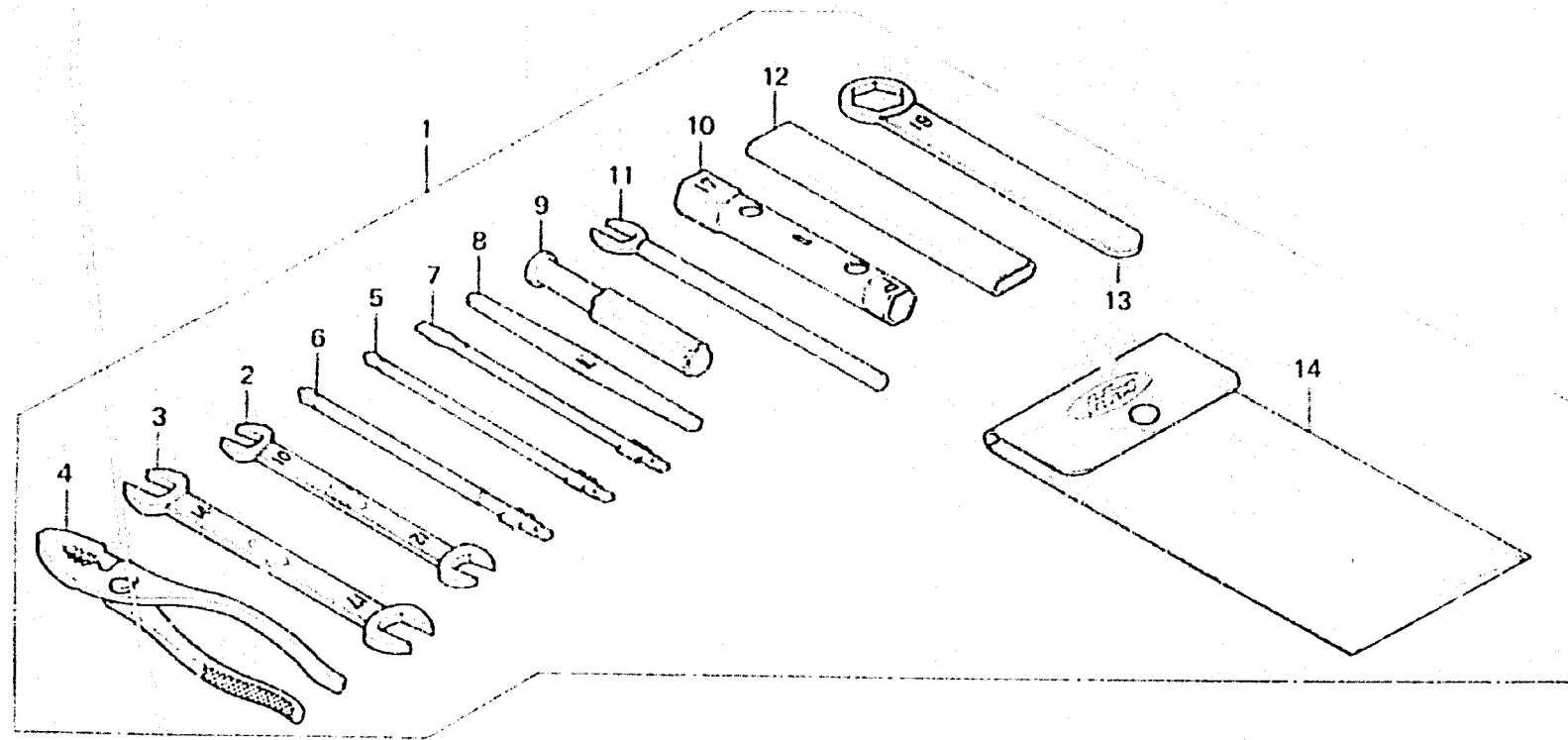

8410-24

Item d'entretien	T.D.R.	N° de réf.	N° de pièce	Description	N° de requis				N° de série	Code de zone
					CM125	CM185	CM125			
					T	T	Tz	Tb		
		1	89010-399-000	JEU D'OUTILS	1	1	1	1		
		2	99001-10120	CLE, 10X12	1	1	1	1		
		3	99001-14170	CLE, 14X17	1	1	1	1		
		4	99002-13500	PINCES, 135	1	1	1	1		
		5	99003-10000	TOURNEVIS 2 DE	1	1	1	1		
		6	99003-20000	TOURNEVIS 3 DE	1	1	1	1		
		7	99003-30000	TOURNEVIS 2 DE (-)	1	1	1	1		
		8	99003-40000	LEVIER	1	1	1	1		
		9	99003-50000	POIGNEE	1	1	1	1		
		10	99004-16170	CLE A DOUILLE, P16X17	1	1	1	1		
		11	99005-02000	BARRE B DE POIGNEE	1	1	1	1		
		12	99006-12000	POIGNEE DE CLE A DEIL, 120MM	1	1	1	1		
		13	99006-19000	CLE A DEIL, 19MM	1	1	1	1		
		14	99008-02000	SAC D'OUTILS, 200MM	1	1	1	1		

1931.02.20

E

L6