

**2-J7**

**F-30**

**Radiator**  
(VF750Cc • Cd • Ce)

**Radiateur**  
(VF750Cc • Cd • Ce)

**Kühler**  
(VF750Cc • Cd • Ce)

**Radiador**  
(VF750Cc • Cd • Ce)

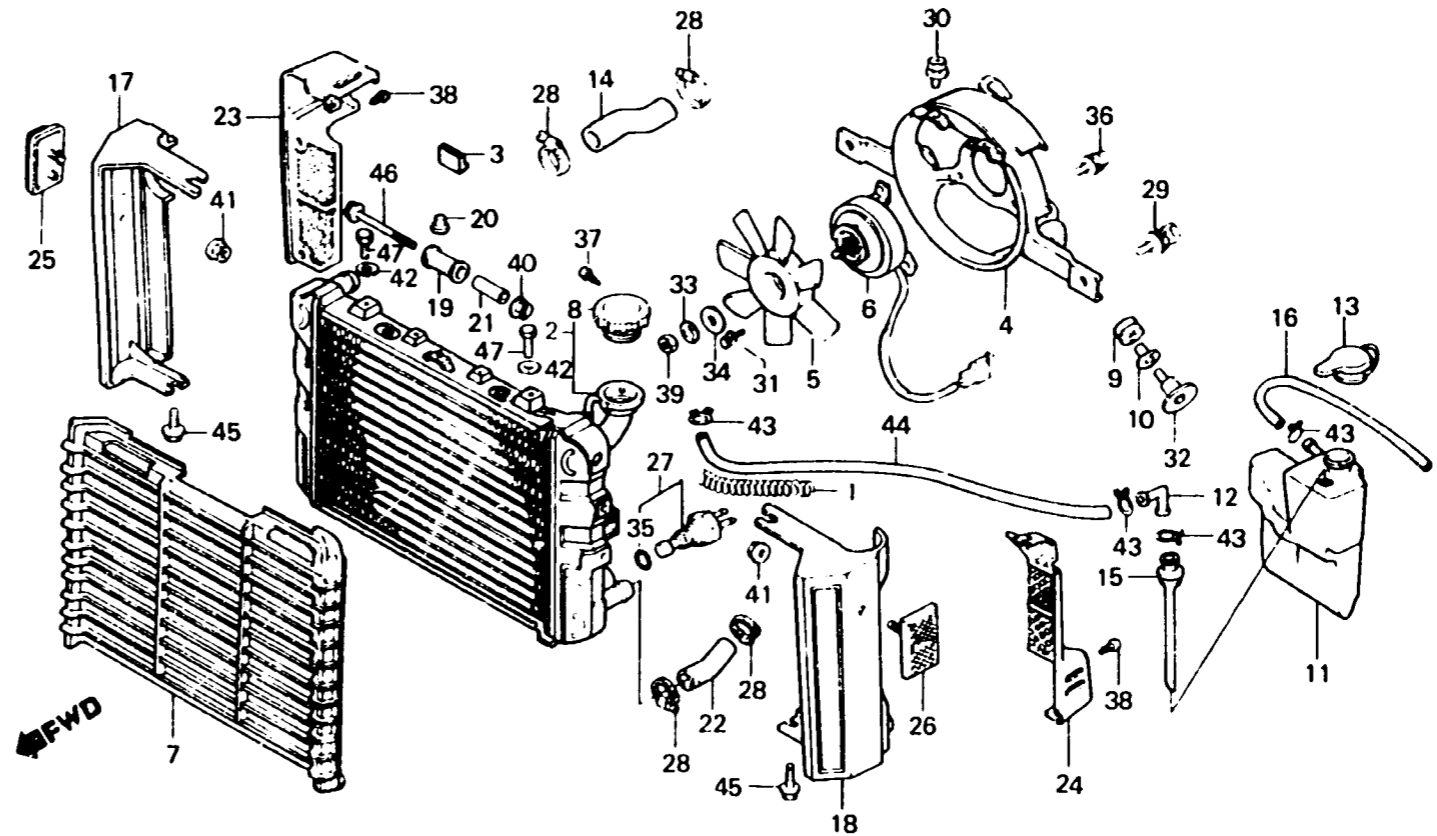

BMB1 - 30E

Item d'entretien	T.D.R.	N° de réf.	N° de pièce	Description	N° de requis					N° de série	Code de zone
					VF750	IV45	MAGNA	Cc	Ce		
		33	90401-679-003	RONDELLE ELASTIQUE, 5MM(ND) .....	1	1	-	-	-	-	CM,E,SA,SW ED,F,G
		34	90402-679-003	RONDELLE PLATE, 5MM(ND) .....	1	1	-	-	-	2102153	ED,F,G,ND CM,E,SA,SW
		35	91307-611-000	JOINT TORIQUE, 13.5X1.4 .....	1	1	1	-	-	-	ED,F,G 2102153
		36	93893-05010-08	VIS A TETE A RONDELLE, 5X10 .....	3	3	3	-	-	2003201	E,ED,F,G,SA
		37	93901-22180	VIS AUTO-TARAUSEUSE, 3X8 .....	1	1	-	-	-	DM115177	CM ED,F,G,ND
		38	93903-35180	VIS AUTO-TARAUSEUSE, 5X10 .....	4	4	4	-	-	-	CM,IT,N,SP,SW
		39	94001-05080-0S	ECROU HEX., 5MM .....	1	1	-	-	-	-	CM,E,SA,SW ED,F,G
			94050-05080	ECROU DE BRIDE, 5MM .....	-	1	-	-	-	2102154	ED,F,G,ND