

Install the newly selected shim on the valve retainer.  
Apply molybdenum disulfide oil to the valve lifters.  
Install the valve lifters into the valve lifter holes.

**NOTE:**

Install the shims and valve lifters in their original locations.

Install the camshaft (page 8-23).

Rotate the camshafts by rotating the crankshaft clockwise several times.

Recheck the valve clearance.

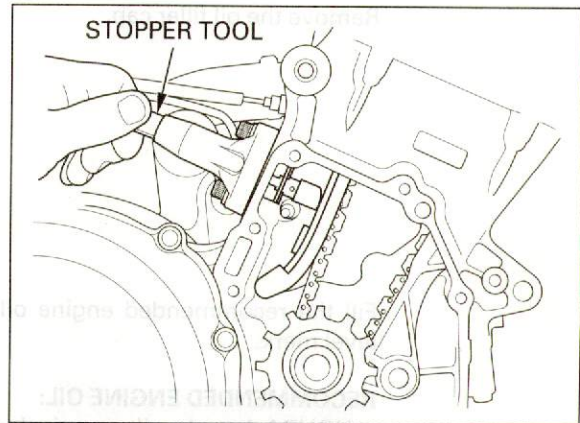

Remove the cam chain tensioner stopper tool.

Install the new sealing washer and cam chain tensioner lifter sealing bolt.  
Tighten the bolt securely.

Install the removed parts in the reverse order of removal.

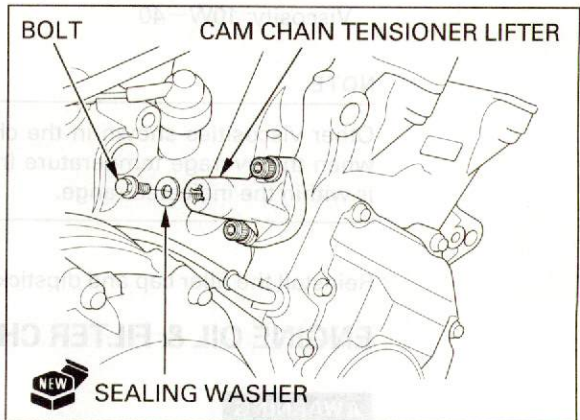

**ENGINE OIL/OIL FILTER**

**OIL LEVEL INSPECTION**

Start the engine and let it idle for 2–3 minutes.  
Turn off the engine and support the motorcycle on its center stand.

Remove the oil level dipstick wipe it clean.  
Reinstall the oil level dipstick, but do not screw it.

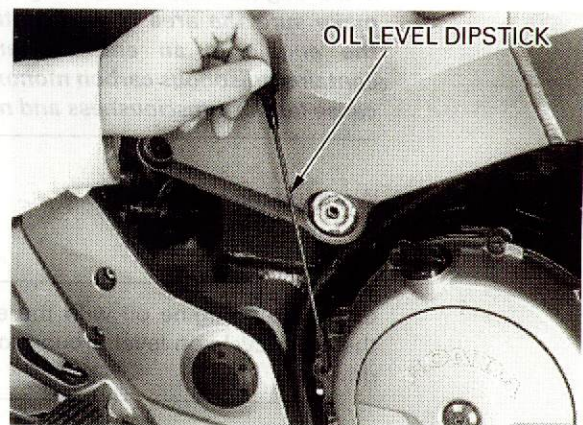

Remove the oil level dipstick and check the oil level.

If the level is below the lower mark on the dipstick, fill the crankcase with recommended oil.

