

## PISTON ASSEMBLY

Clean the piston ring grooves thoroughly and install the piston rings.

**NOTE:**

- Apply oil to the piston rings.
- Avoid piston and piston ring damage during installation.
- Install the piston rings with the marking (R) facing up.
- Do not mix the top and second rings; the top ring is narrower than the second ring in width.

Space the piston ring end gaps 180 degrees apart. Do not align the gaps in the oil rings (side rails).

After installation, the rings should rotate freely in the ring grooves.

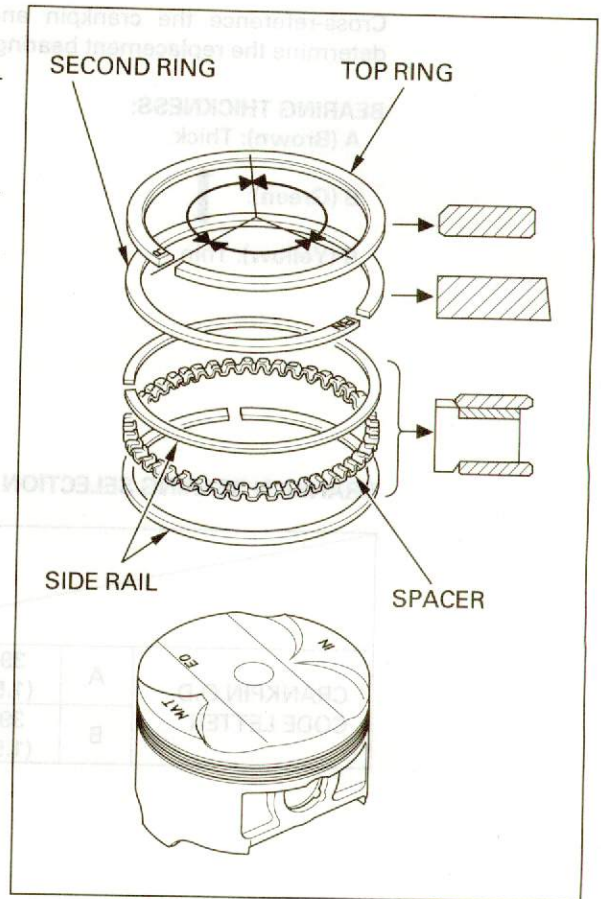

## PISTON INSTALLATION

*Install the connecting rod with its oil hole side facing the "IN" mark on the piston crown.*

Assemble the piston and connecting rod.

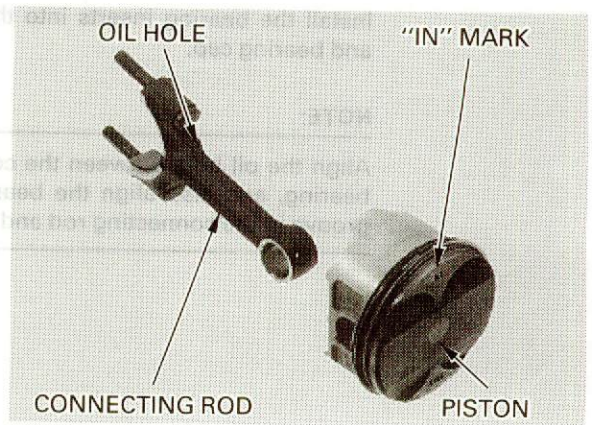

*Do not align the piston pin clips end gap with the piston cut-out.*

Apply molybdenum disulfide oil to the piston pin outer surface. Install the piston pin, and secure it using a new piston pin clips.

