

Remove the primary drive sub-gear and springs.

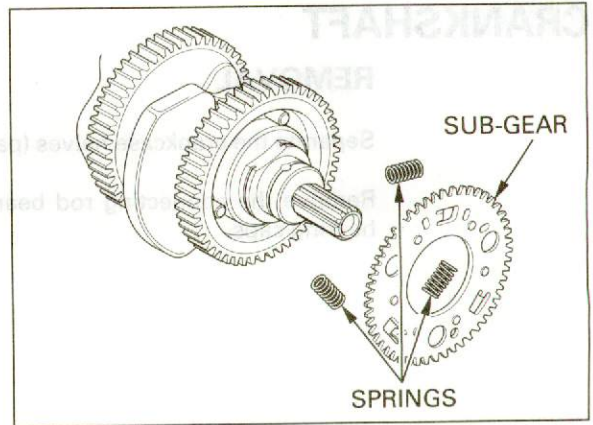

PRIMARY DRIVE SUB-GEAR INSTALLATION

Install the primary drive sub-gear onto the primary drive gear, aligning the holes between the gear.

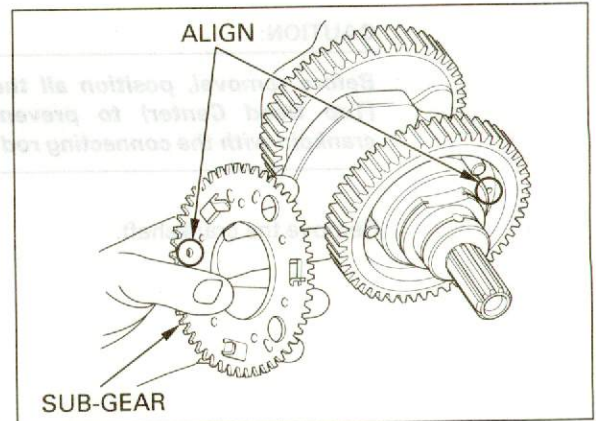

Apply molybdenum disulfide oil to the area shown in the illustration. Install the friction spring, washer and new special snap ring.

CAUTION:

- **You must use the new special snap ring. Using a snap ring other than specified or reusing the snap ring can cause severe engine damage.**
- **Install the new special snap ring with its large tab facing to the right and the chamfered side facing in.**
- **Make sure the new special snap ring end gap is aligned with the right angle of the crankshaft cut-outs as shown.**

