

• VALVE TIMING

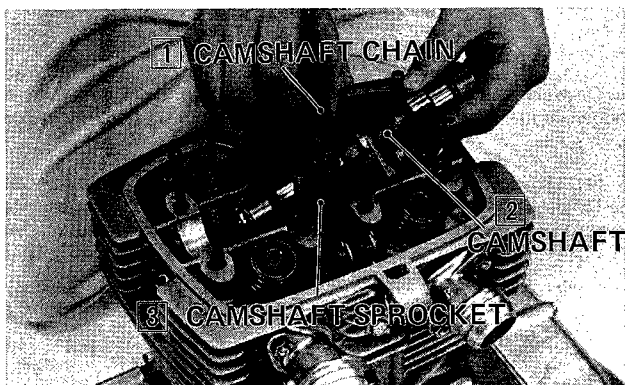

- 4**
- Place the camshaft chain and sprocket on the camshaft at the same time.

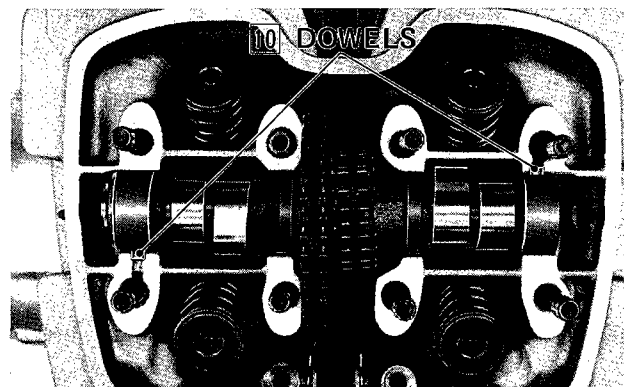

- 5**
- Seat the dowel on the camshaft bushing in the hole in the cylinder head saddle.

- 6**
- (4) Rotate the crankshaft 360° and tighten.
- 1.7 - 2.3 kg-m
(12.29 - 16.63 lbs-ft.)

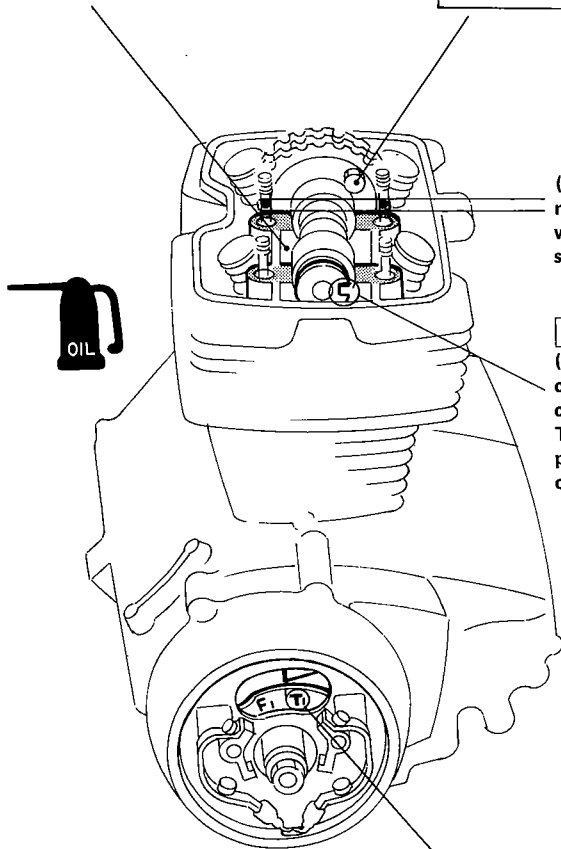

- 7**
- (3) Bring the timing marks in parallel with the camshaft saddle.

- 8**
- (2) Position the camshaft with the cutout on the IN-TAKE side and in parallel with the end of the cylinder head.

- 9**
- (1) Align the "T1" mark with the index mark.

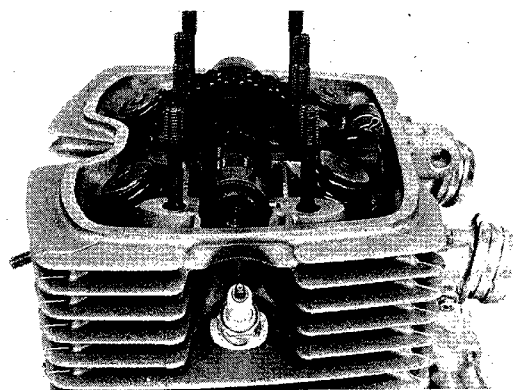

- 11**
- Place the camshaft chain on the sprocket.

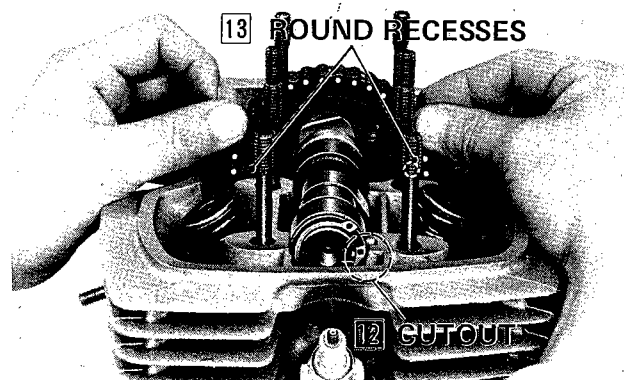

- 14**
- Install the camshaft with the cutout in the shaft end and two round recesses in the sprocket in parallel with the end of the cylinder head.