

b. INSPECTION

• SPARK ADVANCER

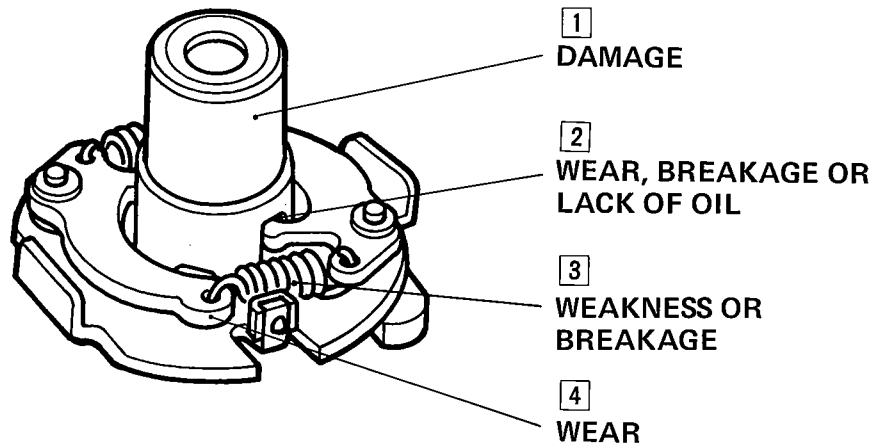

5 **NOTE**
Check to make certain that the weights move freely without binding.

• CONTACT BREAKER POINTS

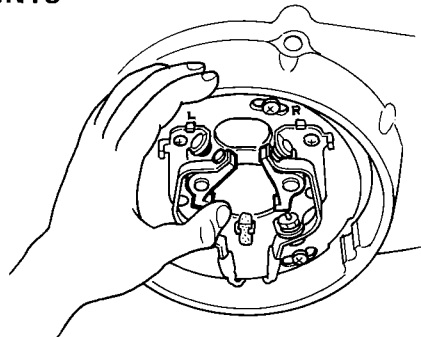

6 Apply a drop or two of oil to the felt wick if it is dry.

7 **MAXIMUM POINT GAP**
Standard 0.3 – 0.4 mm (0.0118 – 0.0158 in.)

8

- Check for burned or oxidized points and replace the points with new one if necessary. Minor roughness can be corrected with a point file.
- Replace the points if excessively worn, out of alignment or pitted badly only on one side.

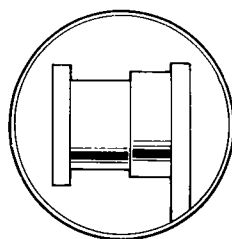

9 GOOD

12 DIRTY

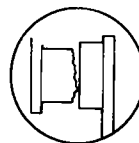

10 CORRECT

13 OUT OF ALIGNMENT

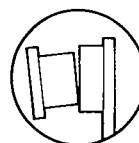

14 WEAR

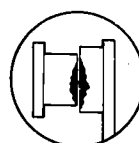

11 REPLACE

15 PITTING ON ONE SIDE

