

Inspection

Refer to service data on page 112.

1. Check the filter screen for contamination or breakage.
2. Check the inside surface of the oil filter rotor for contamination.
3. Measure the oil pump inner-to-outer rotor clearance and the side clearance.

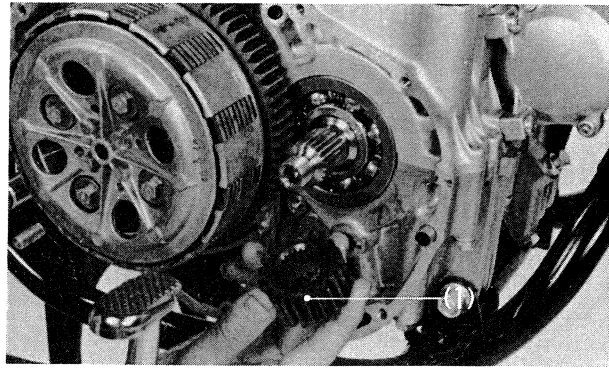

Fig. 4-65 (1) Primary drive gear

Assembly

To assemble, reverse the disassembly procedures paying attention to the following:

1. Install the primary drive gear so that the larger chamfered side faces toward the crankshaft.
2. Install the lock washer with the side marked "OUTSIDE" facing front.
3. Install the lock nut so that the larger chamfered side toward the oil filter.

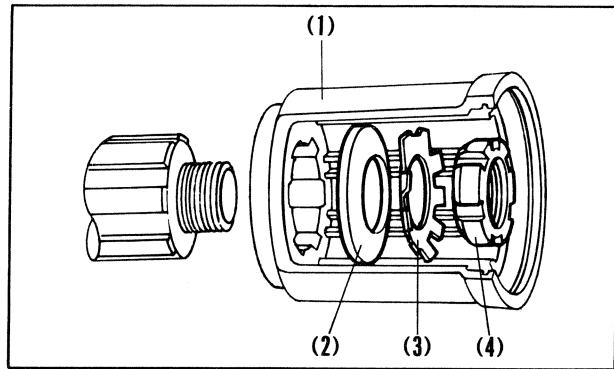

Fig. 4-66 (1) Oil filter rotor (2) Lock washer (3) 16 mm lock washer (4) Lock nut

4. Tighten the lock nut using the lock nut wrench and bend the locking lugs of the lock washer securely.

Specified tightening torque:

4.5–5.5 kg·m (32.6–39.7 lbs-ft)

5. Install the O-ring when installing the oil filter cap. Secure the cap with the snap ring.

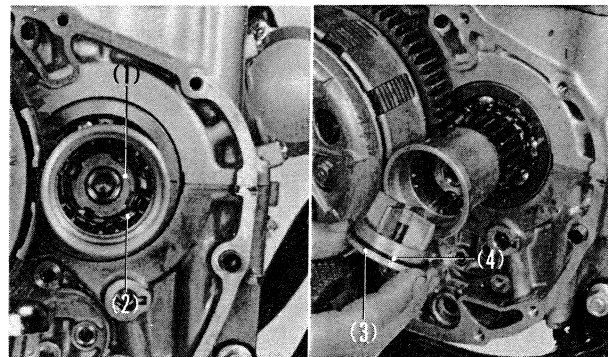

Fig. 4-67 (1) Lock nut (2) 16 mm lock washer (3) Oil filter cap (4) O-ring

6. Install the two O-rings when installing the oil pump.

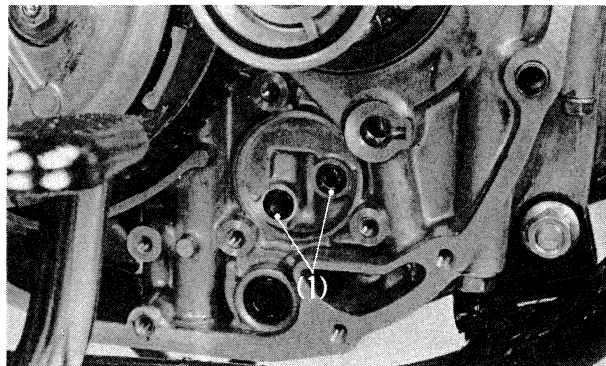

Fig. 4-68 (1) O-ring