

7. Install the filter screen to the oil filter screen and install the assembly to the crankcase.

CAUTION:

Do not forget to install the O-ring.

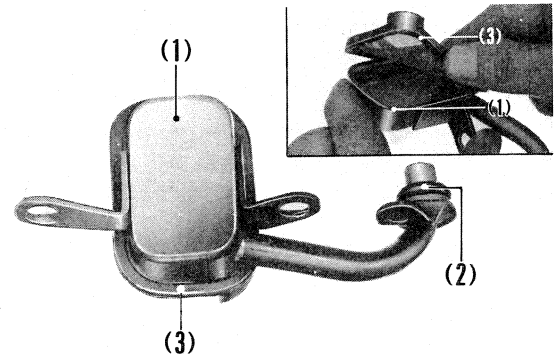
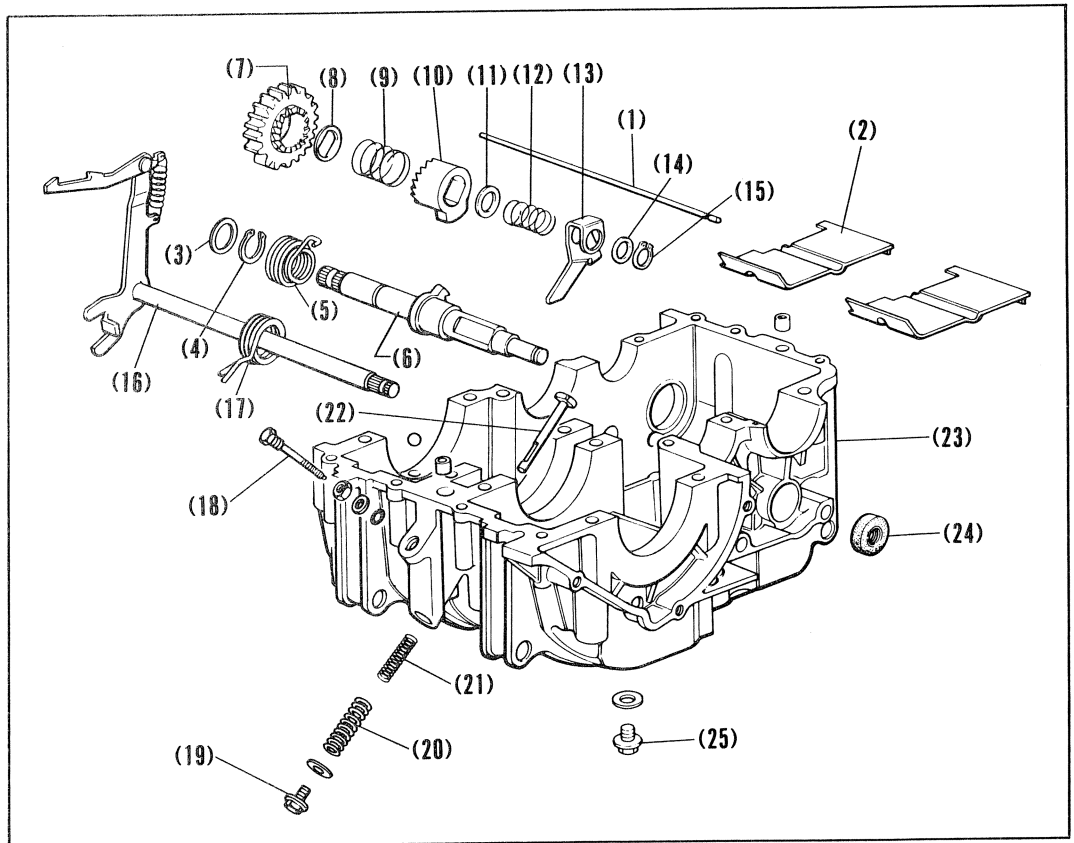

Fig. 4-69 (1) Oil filter screen
(2) O-ring
(3) Filter screen

7. KICK STARTER AND LOWER CRANKCASE

Fig. 4-70

- (1) Oil separator setting bar
- (2) Oil separator
- (3) 18mm washer
- (4) 18mm snap ring
- (5) Kick starter spring
- (6) Kick starter spindle
- (7) Kick starter pinion
- (8) 20mm thrust washer
- (9) Setting spring
- (10) Kick starter ratchet
- (11) 15mm thrust washer
- (12) Ratchet spring
- (13) Ratchet guide plate
- (14) Thrust washer
- (15) 12mm snap ring
- (16) Gear shift spindle
- (17) Gear shift return spring
- (18) Tensioner setting bolt
- (19) Oil check bolt
- (20) Tensioner outer spring
- (21) Tensioner inner spring
- (22) Tensioner push bar
- (23) Lower crankcase
- (24) 14 x 28 x 7 oil seal
- (25) Drain bolt



Disassembly

1. Remove the engine. (See pages 31-33)
2. Remove the left crankcase rear cover and left crankcase cover.
3. Remove the right crankcase cover.
4. Remove the upper crankcase tightening bolt.

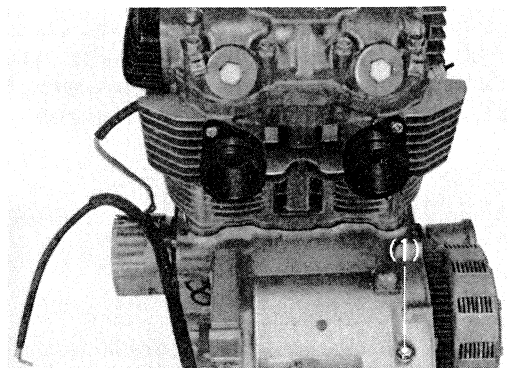

Fig. 4-71 (1) Upper crankcase tightening bolt