

NOTE:

- Soak the thermo sensor in coolant up to its threads with at least 40 mm (1.57 in) from the bottom of the pan to the bottom of the sensor.
- Keep the temperature constant for 3 minutes before testing. A sudden change of temperature will result in incorrect readings. Do not let the thermometer or thermo sensor touch the pan.

Temperature	80 °C (68 °F)	120 °C (248 °F)
Resistance	2.1 – 2.6 kΩ	0.62 – 0.76 kΩ

Replace the sensor if it is out of specification by more than 10% at any temperature listed.

Apply sealant to the thermo sensor threads. Do not apply sealant to the sensor head.

Install and tighten the thermo sensor.

TORQUE: 10 N·m (1.0 kgf·m , 7 lbf·ft)

Connect the thermo sensor connector.

Fill the system and bleed the air (page 6-4).

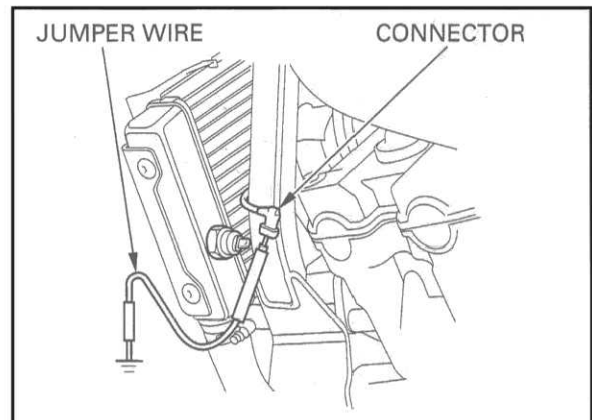
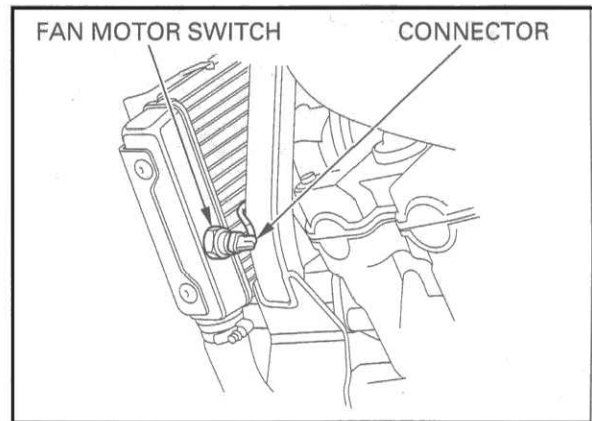
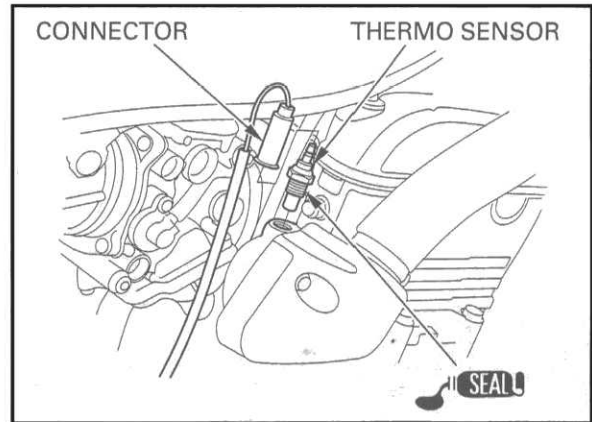
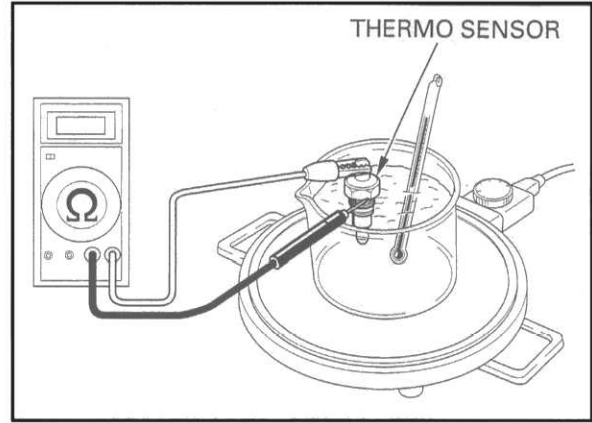

COOLANT FAN MOTOR SWITCH

INSPECTION

Check for a blown fuse before inspection.

Fan motor does not stop

Turn the ignition switch OFF, disconnect the connector from the fan motor switch and turn the ignition switch ON again.

If the fan motor does not stop, check for a shorted wire between the fan motor and switch.

If the fan motor stops, replace the fan motor switch.

Fan motor does not start

Before testing, warm up the engine to operating temperature.

Disconnect the connector from the fan motor switch and ground the connector to the body with a jumper wire.

Turn the ignition switch ON and check the fan motor.

If the motor starts, check the connection at the fan motor switch terminal.

It is OK, replace the fan motor switch.