



CRANKCASE

CRANKCASE ASSEMBLY

Apply molybdenum disulfide grease to the gear fork grooves and the crankshaft main bearings.

GREASE (MOLYBDENUM DISULFIDE)

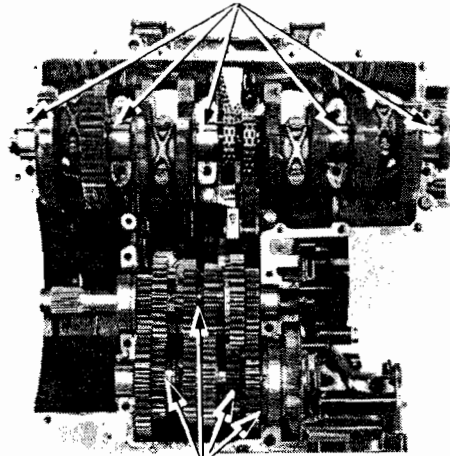

GREASE (MOLYBDENUM DISULFIDE)

Clean the crankcase mating surface and apply liquid sealant to the mating surface of the lower crankcase.

CAUTION

Do not apply sealant to the area near the main bearings and tapered holes.

Install the oil orifice and O-ring into the lower crankcase hole.

O-RING ORIFICE

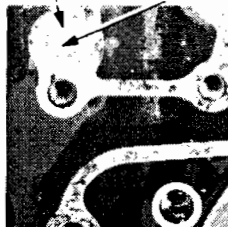

DO NOT COAT THIS AREA.

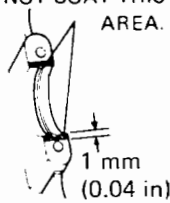

GREASE (MOLYBDENUM DISULFIDE)

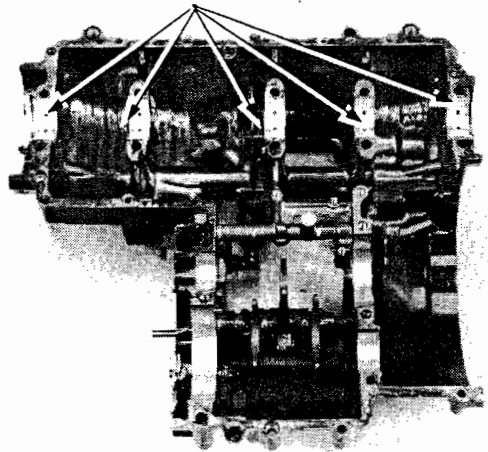

Install the two crankcase assembly pins (07973-ME50000) into the upper crankcase from the outside.

Shift the gearshift linkage into the neutral position for easier assembly, if the gearshift linkage is installed in the lower crankcase.

Place the lower crankcase onto the upper crankcase aligning the pins with the taper holes in the lower crankcase, and the shift fork claws with the transmission gear grooves.

TAPER HOLES

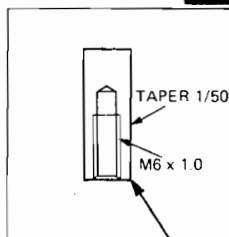
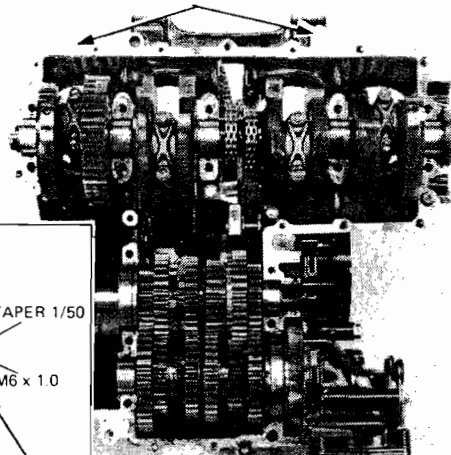

CRANKCASE ASSEMBLY PIN
07973-ME50000