



## FINAL DRIVE

### GEAR TOOTH CONTACT PATTERN CHECK

Remove the oil filler cap from the final gear case.

Rotate the ring gear several times in both direction of rotation.

Check the gear tooth contact pattern through the oil filler hole. The pattern is indicated by the Prussian Blue applied to the pinion before assembly. Contact is normal if Prussian Blue is transferred to the approximate center of each tooth and slightly towards the face.

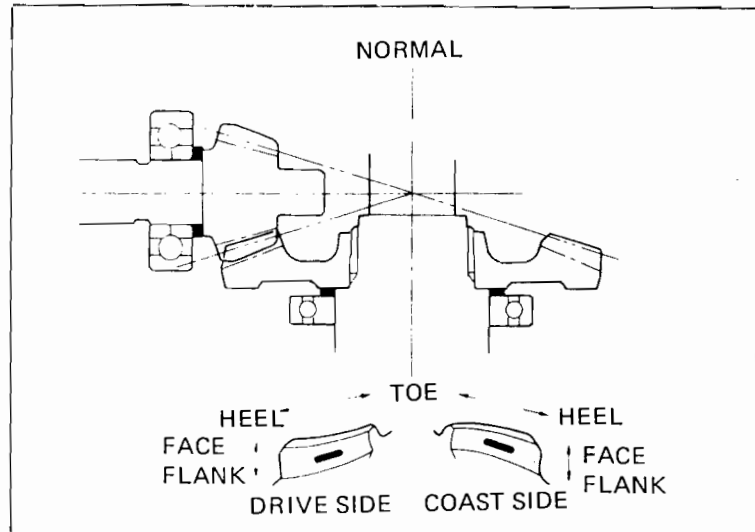

If the patterns are not correct, remove and replace the pinion spacer.

Replace the pinion spacer with a thicker one if the contacts are too high.

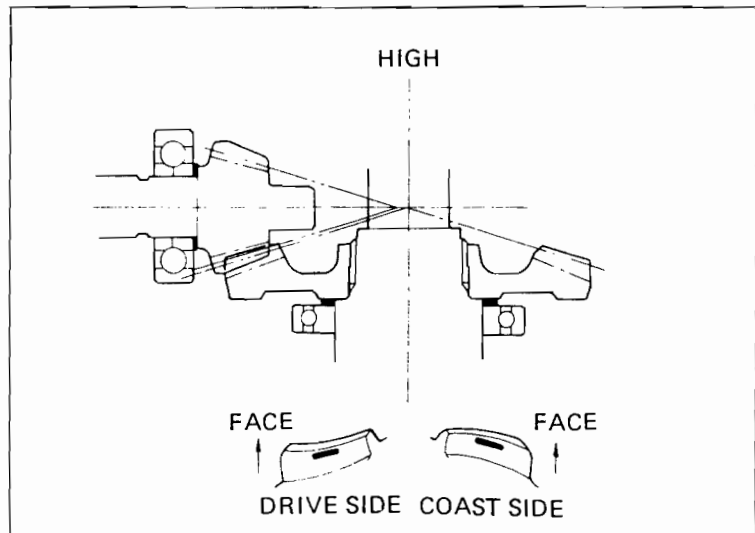

Replace the pinion spacer with a thinner one if the contacts are too low.

The patterns will shift about 1.5–2.0 mm (0.06–0.08 in) when the thickness of the spacer is changed by 0.1 mm (0.004 in).

#### PINION SPACER:

- A 1.82 mm (0.072 in)
- B 1.88 mm (0.074 in)
- C 1.94 mm (0.076 in)
- D 2.00 mm (0.079 in) standard
- E 2.06 mm (0.081 in)
- F 2.12 mm (0.083 in)
- G 2.18 mm (0.086 in)

