

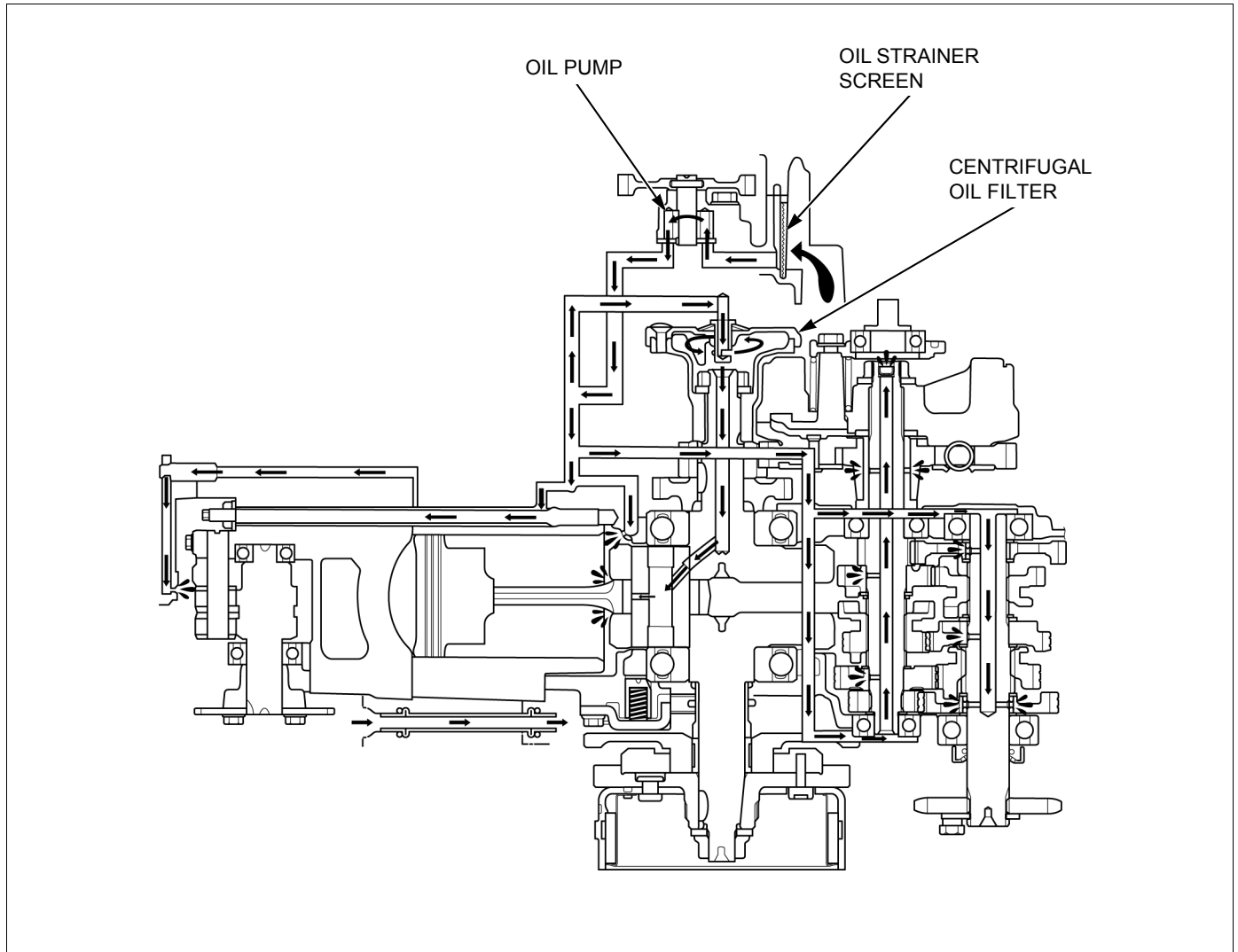

LUBRICATION SYSTEM SYSTEM DIAGRAM

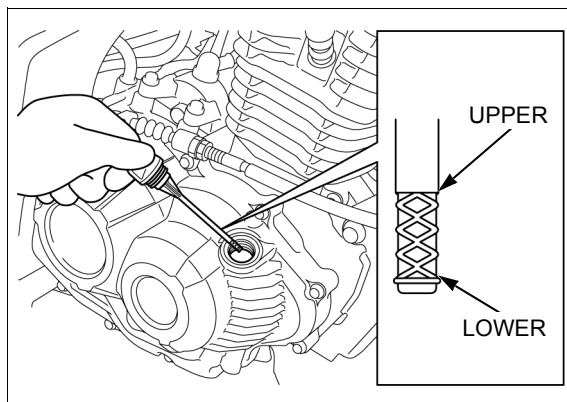

ENGINE OIL LEVEL CHECK



- Place the vehicle on the level ground with its centerstand.
- Let the engine idle for 3 – 5 minutes.



- Wait for 2 – 3 minutes.



- Hold the vehicle in an upright position.
- Clean and insert the oil filler cap/dipstick without screwing it in, remove it and check the oil level.
- If the oil level is below or near the lower level line on the dipstick, add the recommended oil to the upper level.
- Check that the O-ring on the oil filler cap is in good condition, and replace it if necessary.



- **RECOMMENDED ENGINE OIL:**
Honda “4-stroke motorcycle oil” or an equivalent motor oil.

API service classification: SG or higher

JASO T903 standard: MA

Viscosity: SAE 10W-30