

Install the cam chain over the cam sprocket.  
 Install the cam sprockets onto the camshaft flange shoulders while depressing the cam chain tensioner arm with a screwdriver.

**NOTE**

- Make sure that the cam chain is engaged on the sprocket of the crankshaft.

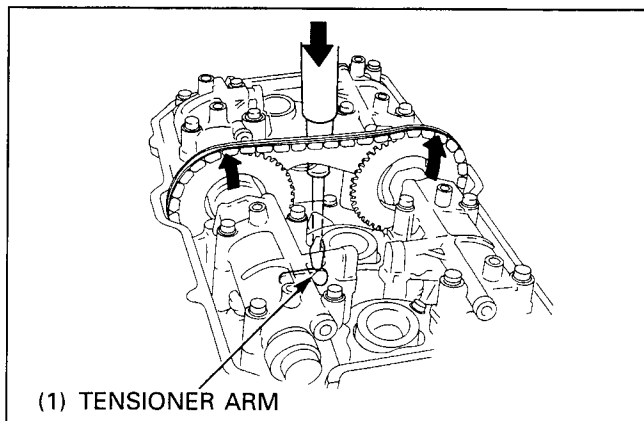

Apply a locking agent to the threads of the sprocket bolts.  
 Align the cam sprocket bolt holes by turning the camshaft slightly and install the cam sprocket bolts.  
 Tighten the sprocket bolts, rotate the crankshaft one revolution and tighten the other bolts.

**Torque: 17 N · m (1.7 kg-m, 12 lb-ft)**

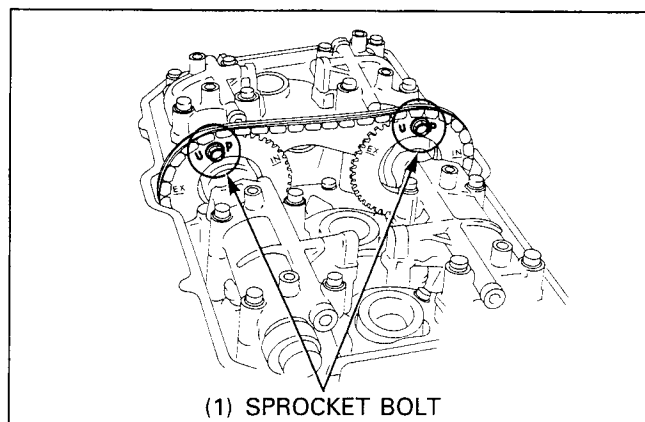

Realign the index mark on the ignition pulse generator rotor with the "T" mark on the crankcase.  
 Make sure that the "IN" and "EX" marks on the sprockets align with the cylinder head upper surface.

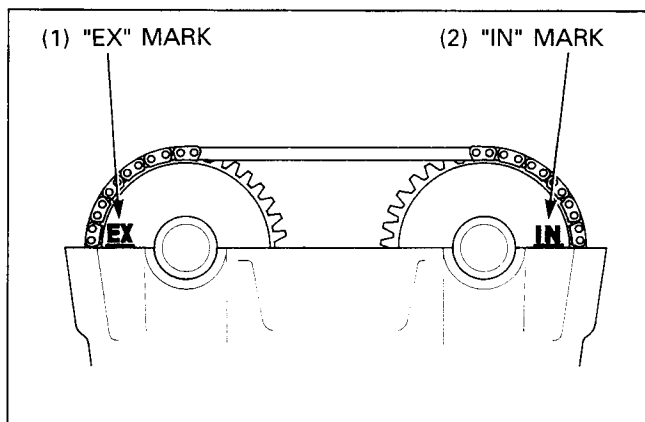

Fill the cam chain tensioner oil chamber with clean engine oil .

Recheck valve timing.

