

ENGINE (Cont'd)

ITEM	Q'TY	THREAD DIA. (mm)	TORQUE N-m (kgf-m, lbf-ft)	REMARKS
IGNITION SYSTEM: Ignition pulse generator cover SH bolt	8	6	12 (1.2 , 9)	NOTE 1 See page 1-20 NOTE 5
Ignition pulse generator rotor special bolt	1	10	59 (6.0 , 43)	
LIGHT/METERS/SWITCHES: Neutral switch	1	10	12 (1.2 , 9)	

Throttle body insulator clamp:

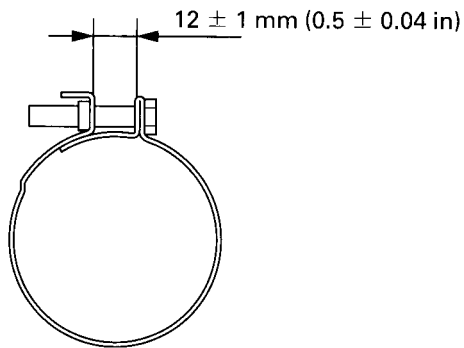

Exhaust pipe stud bolt:

