

With the ignition coil primary wire connected, connect the peak voltage adaptor or Imrie tester to the ignition coil.

CONNECTION:

No. 1/4 coil:

Yellow/Blue terminal (+) – Body ground (-)

No. 2/3 coil:

Blue/Yellow terminal (+) – Body ground (-)

Turn the ignition switch "ON" and engine stop switch to "RUN".

Check for initial voltage at this time.

The battery voltage should be measured.

If the initial voltage cannot be measured, check the power supply circuit (refer to the troubleshooting, page 17-3).

Crank the engine with the starter motor and read ignition coil primary peak voltage.

PEAK VOLTAGE: 100 V minimum

If the peak voltage is abnormal, check for an open circuit or poor connection in Yellow/Blue and Blue/Yellow wires.

If not defects are found in the harness, refer to the troubleshooting chart on page 17-3.

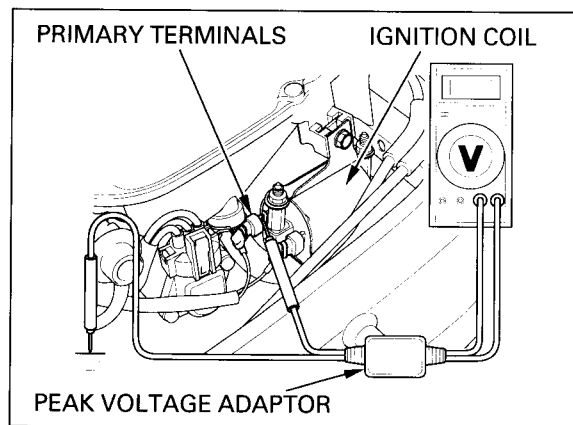

IGNITION PULSE GENERATOR PEAK VOLTAGE

⚠ WARNING

Avoid touching the spark plugs and tester probes to prevent electric shock.

NOTE:

- Check all system connection before inspection. If the system is disconnected, incorrect peak voltage might be measured.
- Check cylinder compression and check that the spark plugs are installed correctly.

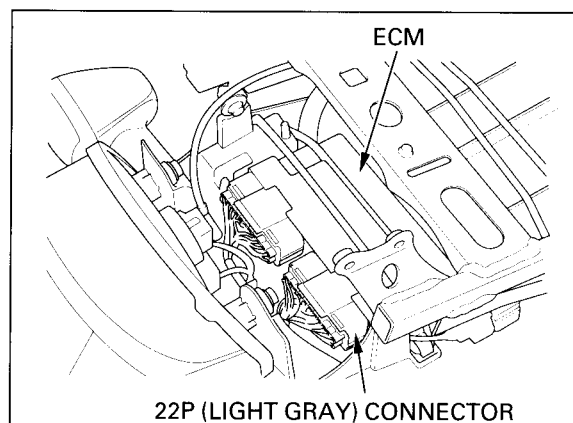

Remove the seat (page 2-2).

Disconnect the 22P (Light gray) connector from the ECM.