

TACHOMETER

INSPECTION

Remove the upper cowl (page 2-8).

Check for loose or poor contact terminals of the combination meter.

Connect the peak voltage adaptor to the tachometer Black/Yellow terminal and ground.

TOOLS:

**Imrie diagnostic tester (model 625) or
Peak voltage adaptor 07HGJ-0020100
with Commercially available digital multimeter
(impedance 10 M Ω /DCV minimum)**

CONNECTION: Yellow/Green (+) and Ground (-)

Start the engine and measure the tachometer input voltage.

PEAK VOLTAGE: 10.5 V minimum

If the value is normal, replace the tachometer.
If the measured value is below 10.5 V, replace the ECM.

If the value is 0 V, perform the following:
Remove the seat (page 2-2) and disconnect the ECM multi-connector.

Check for continuity between the tachometer terminal and the ECM multi-connector Yellow/Green terminals.

If there is no continuity, check the wire harness for an open circuit.

If there is continuity, replace the tachometer unit.

For tachometer replacement, see 19-8; combination meter disassembly and assembly.

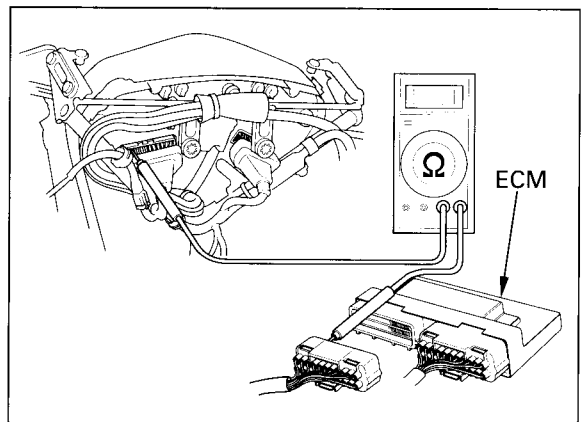
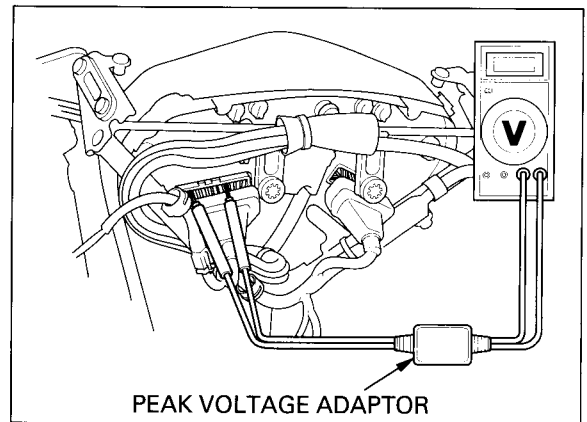
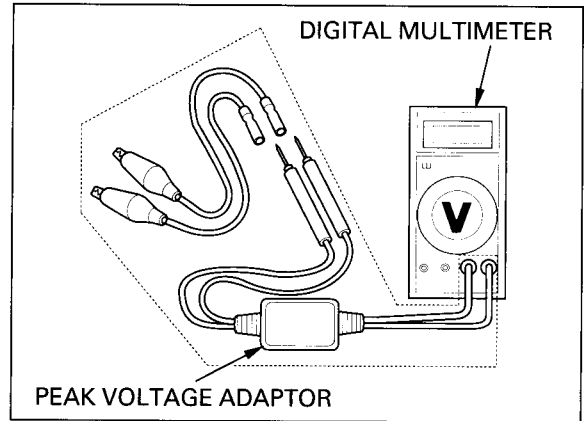

COOLANT TEMPERATURE GAUGE/SENSOR

INSPECTION

Support the front end of the fuel tank (page 3-5).

Disconnect the ECT/thermo sensor wire connector from the sensor.

