

Set the front balancer assembly onto the crankshaft drive gear while aligning its index groove with the boss on the lower crankcase.

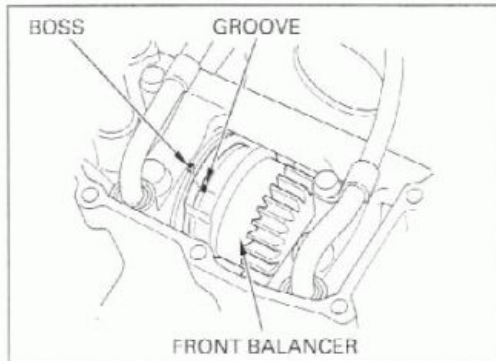

NOTE:

Make sure the No. 1 piston at TDC.

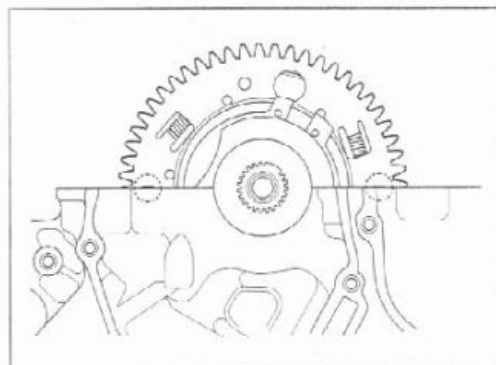

Install a new O-ring into the groove of the front balancer shaft.
Apply small amount of oil to the O-ring.

Install the front balancer shaft with its punch mark facing down.

NOTE:

The front balancer shaft will only installed one particular position. Rotate it until it installed easily; do not force it in.

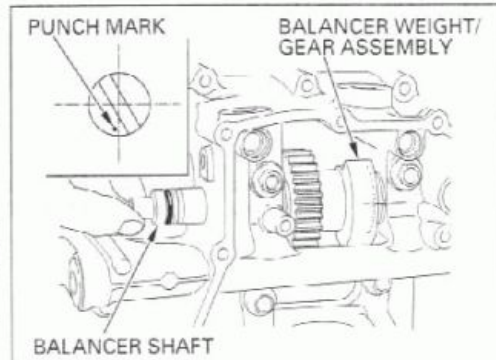

Install the front balancer shaft holder and tighten the holder bolt to the specified torque.

TORQUE: 27 N·m (2.8 kgf·m , 20 lbf·ft)

