

CYLINDER HEAD/VALVES

Using a 45-degree seat cutter, cut the seat to the proper width. Make sure that all pitting and irregularities are removed. Refinish if necessary.

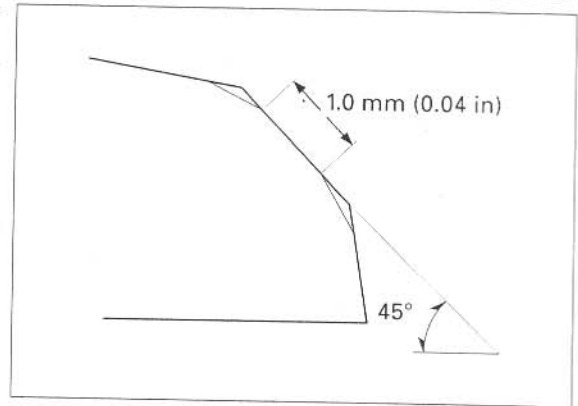

After cutting the seat, apply lapping compound to the valve face, and lap the valve using light pressure.

- Excessive lapping pressure may deform or damage the seat.
- Change the angle of lapping tool frequently to prevent uneven seat wear.
- Do not allow lapping compound to enter the guides.

After lapping, wash all residual compound off the cylinder head and valve.

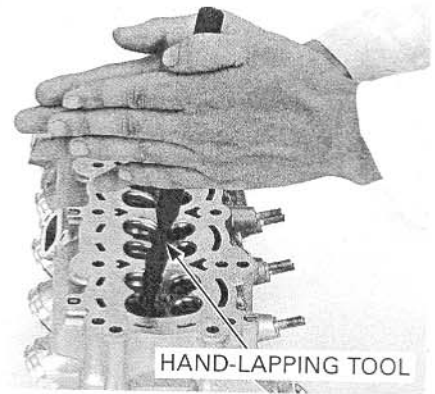

CYLINDER HEAD ASSEMBLY

