

(1) BUSHING

**Right Fork Inspection**

Check the following items (page 1-4):

- Fork tube for score marks, scratches and excessive wear
- Fork tube runout
- Fork slider for damage or deformation
- Fork damper for damage

**Bushing/Back-up Ring**

Check the bushings for excessive wear or scratches. Remove any metal powder inside the slider and guide bushings with a nylon brush and fork fluid. If copper appears on the entire surface, replace the bushing.

Replace the back-up ring if there is any distortion at the points shown.

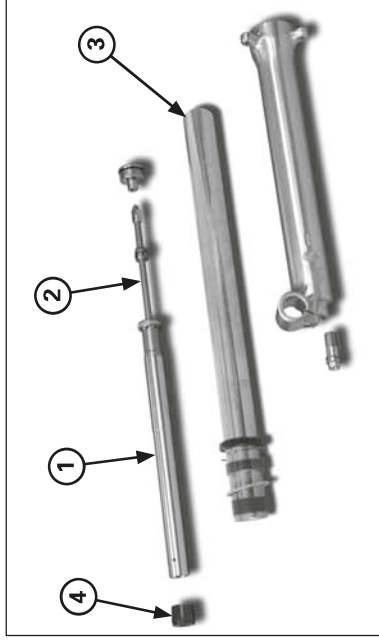

(1) FORK DAMPER  
(2) DAMPER ROD  
(3) FORK TUBE  
(4) CENTERING PLATE

**Fork Damper**

Check the fork damper assembly for damage or deformation. Check the damper rod for bend or other damage.

**Fork tube/centering plate**

Check the fork tube for bent or deformation. Check the centering plate for damage.

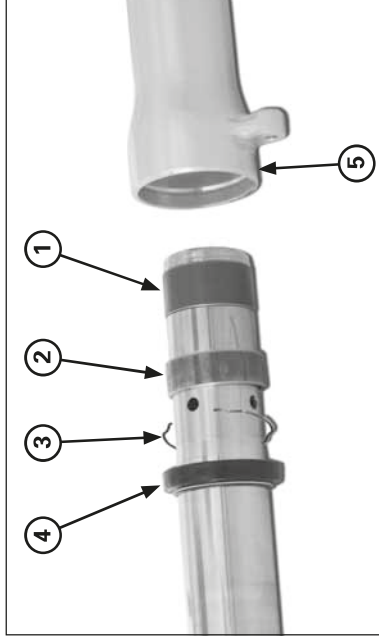

(1) FORK TUBE BUSHING  
(2) GUIDE BUSHING  
(3) BACK-UP RING  
(4) OIL SEAL  
(5) FORK SLIDER

**Right Fork Assembly**

Clean the parts thoroughly with non-flammable or high flush point solvent before assembly.

Install the following to the fork tube:

- Fork tube bushing
- Guide bushing
- Back-up ring

Coat the guide and fork tube bushings with recommended fork fluid.

Install the fork tube assembly into the slider.