

# Carburetor Synchronization

## NOTE

- For detailed instructions, refer to section 2 of the Common Service Manual. The information here only indicates locations of the plugs for the adapters and the synchronization adjusting screws.
- Synchronize the carburetors with the engine at normal operating temperature, the transmission in neutral and the motorcycle in an upright position.

Carburetor vacuum difference: Within 20 mmHg (0.8 inHg)

Base carburetor: '90-'93: No. 2 carburetor  
After '93: No. 1 carburetor

## Idle speed:

('90-'93)

49 state/Canada type:  $1,000 \pm 100$  rpm

California type:  $1,200 \pm 100$  rpm

(After '93)

49 state type:  $1,100 \pm 100$  rpm

California type:  $1,200 \pm 100$  rpm

Canada type:  $1,000 \pm 100$  rpm

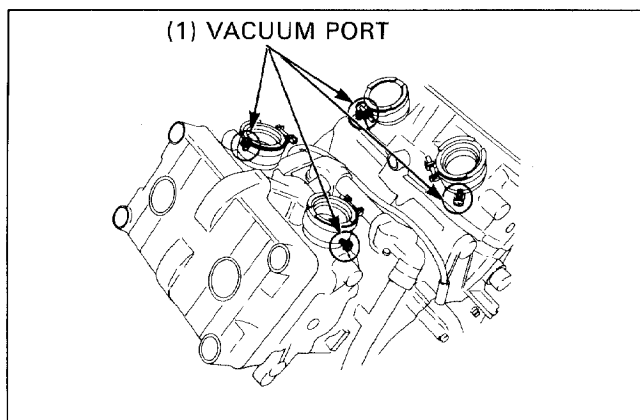

'90-'93:

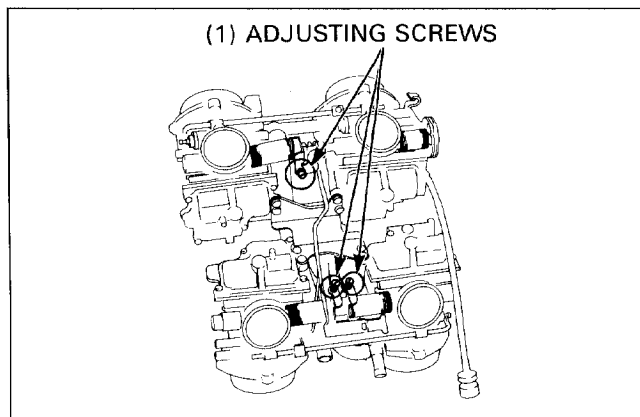

After '93:

