

Rear Wheel Removal/Installation

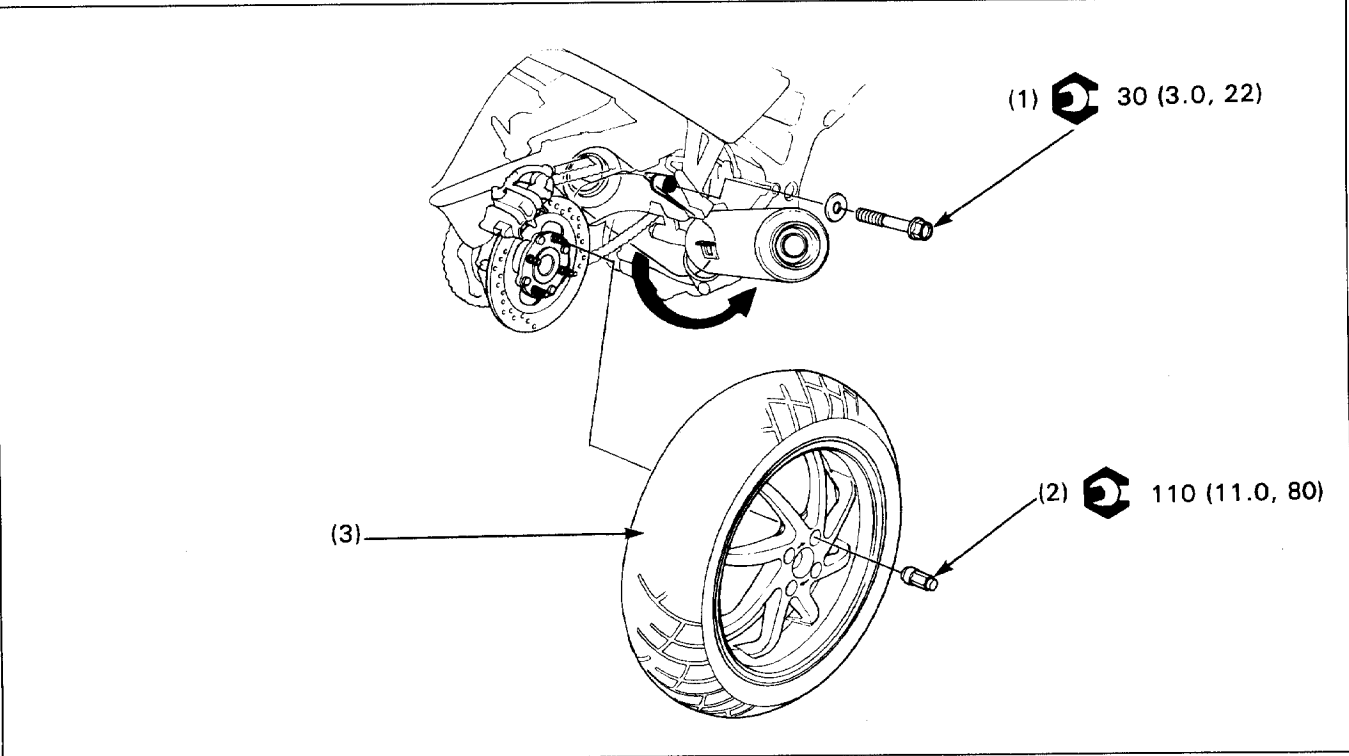

⚠ WARNING

- A contaminated brake disc or pad reduces stopping power. Discard contaminated pads and clean a contaminated disc with a high quality brake degreasing agent.
- Inhaled asbestos fibers have been found to cause respiratory disease and cancer. Never use an air hose or dry brush to clean brake assemblies. Use an OSHA-approved vacuum cleaner or alternate method approved by OSHA designed to minimize the hazard caused by airborne asbestos fibers.

NOTE

- Support the motorcycle by placing a support block under the exhaust system or with the optional center stand.
- Do not depress the brake pedal when the caliper is removed, or it will be difficult to refit the disc between the brake pads.
- Support the removed caliper with a piece of wire so that it does not hang from the brake hose.
- Adjust the drive chain free play after installing the wheel.

Procedure	Q'ty	Remarks
Removal Order		• Installation is in the reverse order of removal.
(1) Muffler mounting bolt	1	After removing, move the muffler away from the rear wheel to the direction shown by arrow.
(2) Rear wheel nut	4	Loosen while applying rear brake.
(3) Rear wheel	1	