

- Remove the spring from the slave cylinder.
- Remove the oil and piston seals.
- Clean the piston groove with clutch fluid.
- Check the piston spring for weakness or damage.

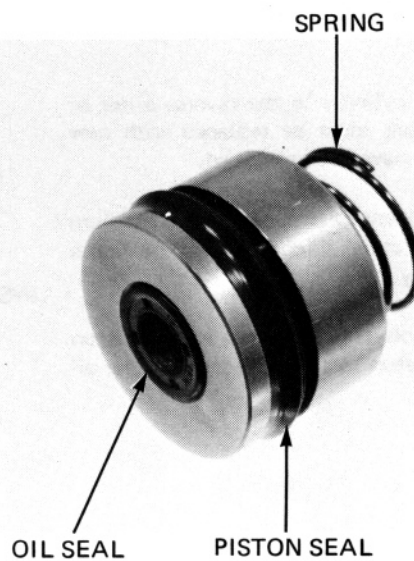

PISTON O.D. INSPECTION

Check the piston for scoring or scratches.
Measure the outside diameter of the piston with a micrometer.

SERVICE LIMIT: 38.02 mm (1.497 in)

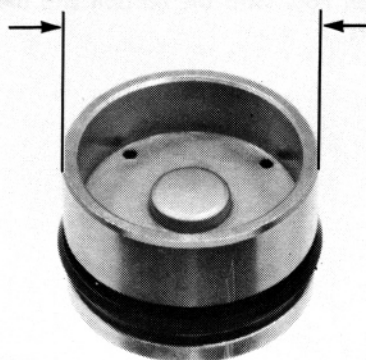

CYLINDER I.D. INSPECTION

Check the slave cylinder for scoring or scratches.
Measure the inside diameter of the cylinder bore.

SERVICE LIMIT: 38.18 mm (1.503 in)

