

CYLINDER HEAD/VALVE

Rotate the crankshaft clockwise and align the timing mark on the rotor with the index mark on the right crankcase.

Install the cylinder head cover.

Check that the slots in the exhaust and intake rocker arm shafts are within the limits shown.

If not, repeat the preceding step and recheck.

NOTE:

Both intake rocker arm shafts should fall within the same limits.

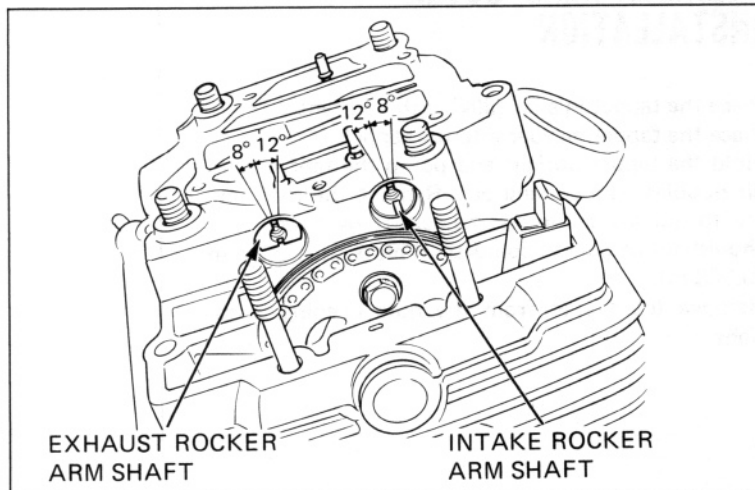

Torque the cylinder head cover bolts and cap nuts.

NOTE:

Tighten the bolts and cap nuts in a criss-cross pattern in 2–3 steps.

TORQUES:

10 mm cap nut: 35–45 N·m
(3.5–4.5 kg·m, 25–33 ft·lb)

8 mm bolt: 20–25 N·m
(2.0–2.5 kg·m, 14–18 ft·lb)

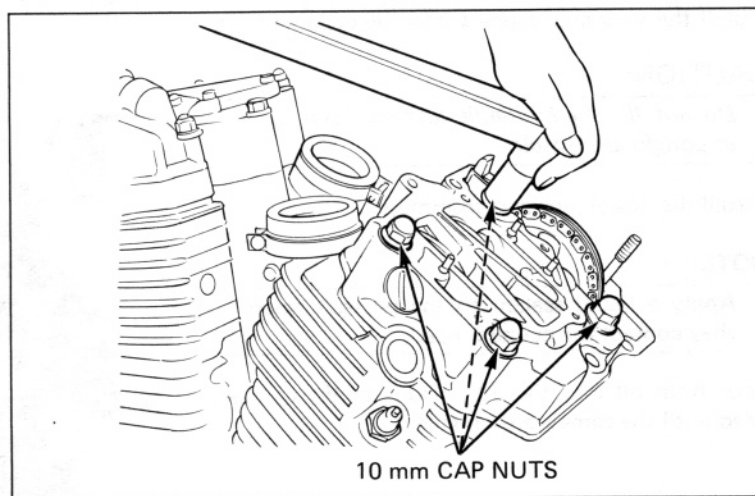

Fill the de-foaming chamber in the head cover with fresh engine oil.

