

DRIVE TRAIN

Install a new O-ring onto the O-ring guide.

Apply grease to the O-ring and drive the O-ring guide onto the ring gear shaft.

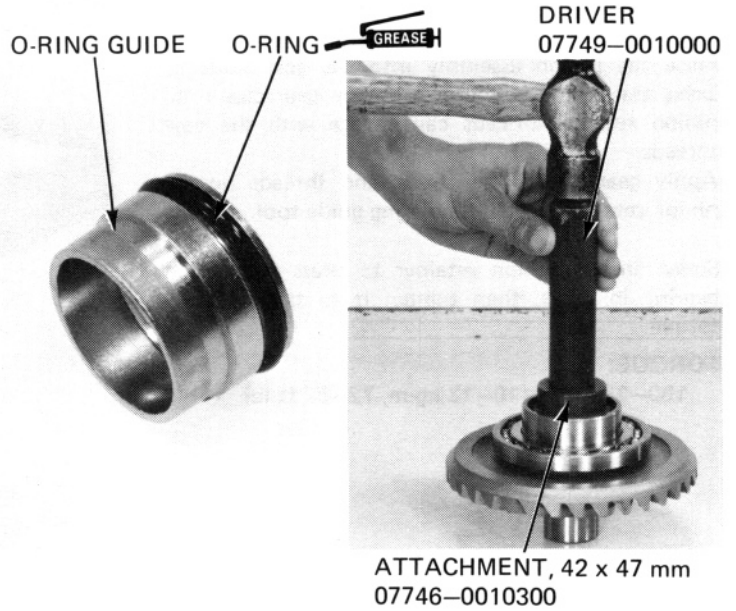

Install the ring gear into the gear case cover. Measure the clearance between the ring gear and the ring gear stop pin with a feeler gauge.

CLEARANCE: 0.30–0.60 mm (0.012–0.024 in)

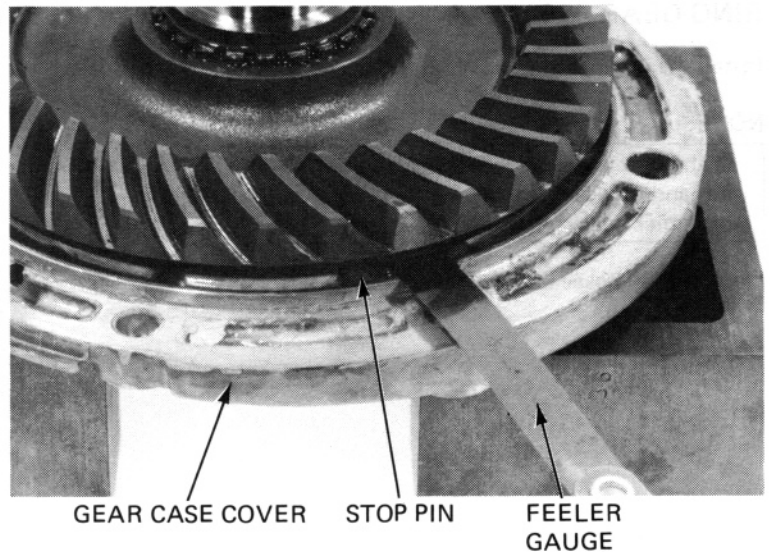

Remove the ring gear. If the clearance exceeds the service limit, heat the gear case cover to approximately 80°C (176°F) and remove the stop pin by tapping the cover.

WARNING

Always wear gloves when handling the gear case after it has been heated.

Install a stop pin shim to obtain the correct clearance.

**SHIM THICKNESS: A: 0.10 mm (0.004 in)
B: 0.15 mm (0.006 in)**

Install the shim and drive the stop pin into the case cover.

