

INSTALLATION

Carefully install the piston rings into the piston ring grooves with the markings facing up.

- Do not damage the piston ring by spreading the ends too far.
- Be careful not to scratch the piston surface.
- Do not confuse the top and second rings.

Stagger the ring end gaps 120 degrees apart from each other.
Stagger the side rail end gaps as shown.

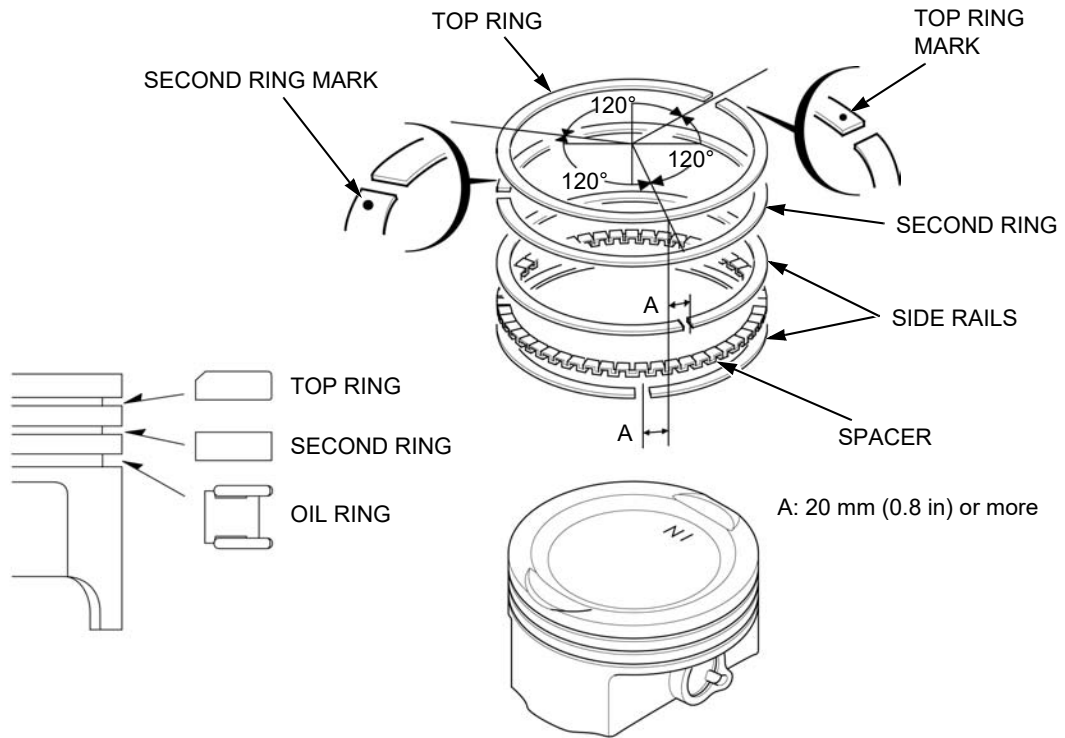

Apply molybdenum oil solution to the piston pin outer surface and connecting rod small end inner surface.
Apply engine oil to the piston pin hole [1].
Install the piston [2] with its "IN" mark [3] toward the intake side and insert the piston pin [4] through the piston and connecting rod.

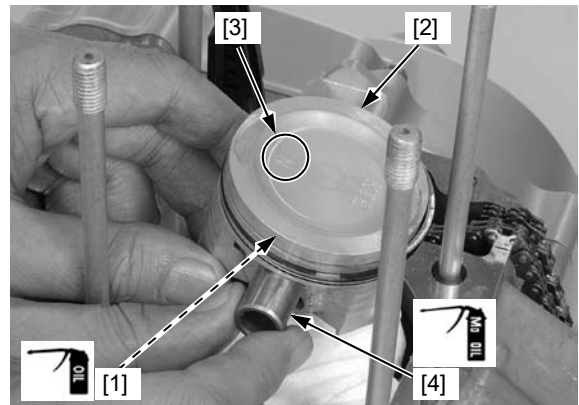

Place a shop towel over the crankcase opening to prevent piston pin clips from falling into the crankcase.

Install new piston pin clips [1] into the grooves in the piston pin hole.

- Make sure that the piston pin clips are seated securely.
- Do not align the piston pin clip end gap with the piston cutout.

