

FRONT WHEEL/BRAKE/SUSPENSION/STEERING

Tighten the bottom bridge pinch bolts [1] to the specified torque.

TORQUE: 32 N·m (3.3 kgf·m, 24 lbf·ft)

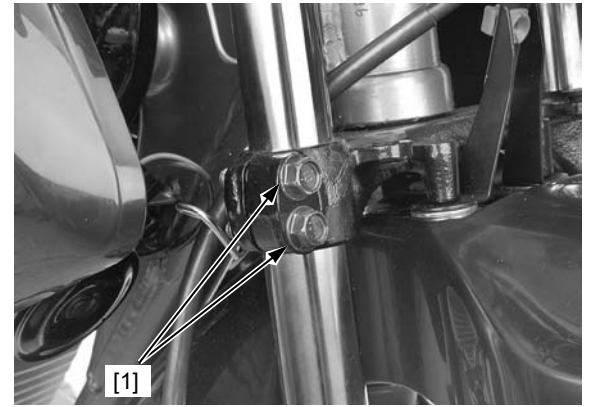

Tighten the fork cap [1] to the specified torque.

TORQUE: 22 N·m (2.2 kgf·m, 16 lbf·ft)

Tighten the top bridge pinch bolt [2] to the specified torque.

TORQUE: 22 N·m (2.2 kgf·m, 16 lbf·ft)

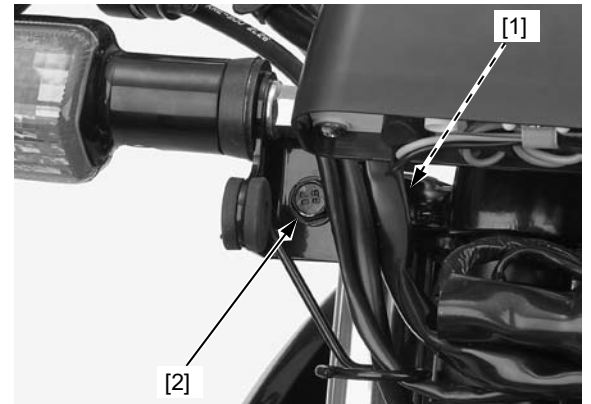

XL125LK: Seat the upper end of the boot [1] on the bottom bridge. Tighten the boot band screw [2].

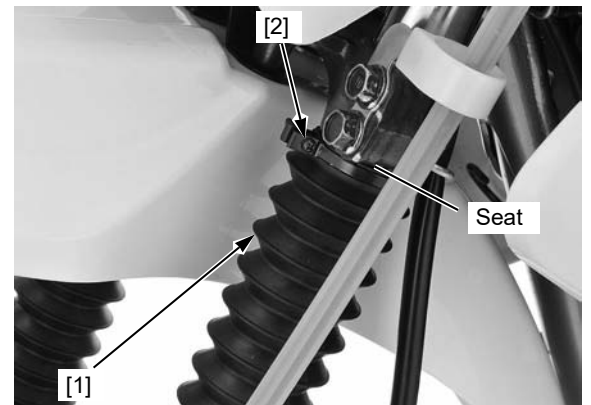

XR125LK/LEK: Install the brake caliper [1] with new mounting bolts [2], and then tighten the bolts to the specified torque.

TORQUE: 30 N·m (3.1 kgf·m, 22 lbf·ft)

Install the brake hose clamps [3], cover [4] and bolts [5]. Tighten the bolts securely.

Install the front wheel (page 14-9).

