

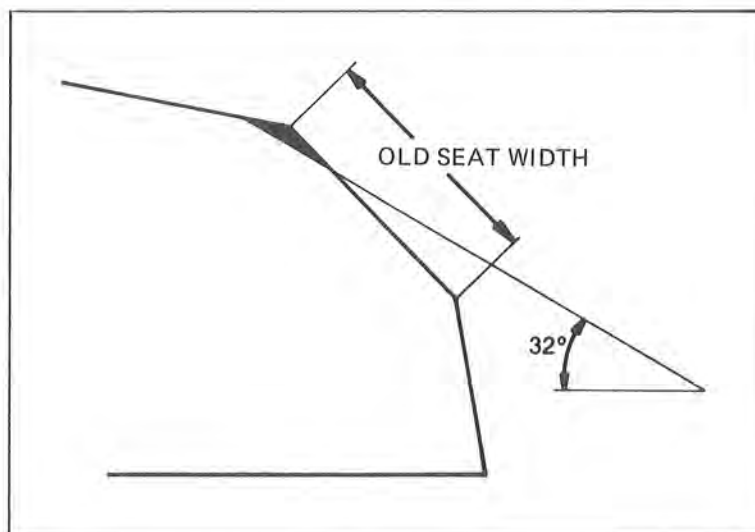

**CYLINDER HEAD/VALVES**

Using a 32 degree cutter, remove 1/4 of the existing valve seat material.



Use a 60 degree cutter and remove the bottom 1/4 of the old seat.

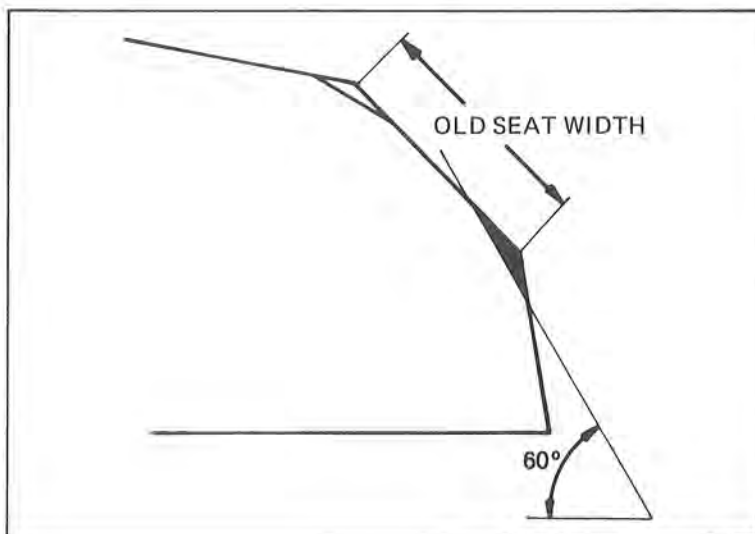

Use a 45 degree finish cutter and cut the seat to the proper width.

**NOTE**

Make sure that all pitting and irregularities are removed. Refinish if necessary.

